

Draka UC Connectivity

Draka Double Gang Curved Edge Euro Size Faceplate 146mm x 86mm - White Part Number - YFPBP03676

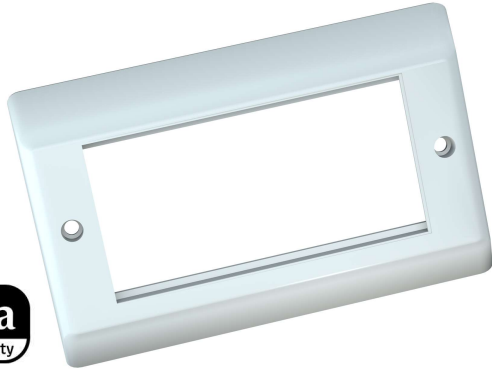

Overview

- Plastic Free Eco-Packaging – Pack of 12
- Double Gang Curved Edge Euro wall faceplate
- Supplied with x2 fixing screws
- Up to 4 Euro modules/keystone adaptors with jacks
- White

Product Description

Draka Double Gang Curved Edge Faceplates with a 100mm x 50mm aperture opening accept x4 standard 25x50mm Euro type modules, or keystone adapters for use in conjunction with the Draka Cat5e/Cat6/Cat6a keystone jacks. The Draka Double Gang Curved Edge Faceplate can also be assembled with our range of Blanking plates which are available in half/quarter sizes to fill opening spaces when not in use.

Draka Curved Edge Faceplates are also available in Single Gang 86mm x 86mm with a 50 x 50 aperture opening for x2 standard 25mm x 50mm Euro type modules, or keystone adapters for use in conjunction with the Draka Cat5e/Cat6/Cat6a keystone jacks.

Product Specification

Faceplate Material	Plastic ABS, UL94HB
Temperature Range	-10°C to 60°C
Colour	White RAL 9003
Fastening	Screw Type
Surface	Curved Edge
Width x Height	146mm x 86mm
Aperture Size	100mm x 50mm
No of units	4

© PRYSMIAN GROUP 2020, All Rights Reserved

All sizes and values without tolerances are reference values. Specifications are for product as supplied by Prysmian: any modification or alteration afterwards of product may give different result.

The information contained within this document must not be copied, reprinted or reproduced in any form, either wholly or in part, without the written consent of Prysmian. The information is believed to be correct at the time of issue. Prysmian reserves the right to amend this specification without prior notice. This specification is not contractually valid unless specifically authorised by Prysmian.

Standards Complied

BSEN 60670-1:2005 + A1:2013	Boxes and enclosures for electrical accessories for household and similar fixed electrical installations general requirements
BSEN 61340-5-1:2007	Protection of electronic devices from electrostatic phenomena. General requirements apply to activities that: manufacture, process, assemble, install, package, label, service, test, inspect, transport or otherwise handle electrical or electronic parts, assemblies and equipment susceptible to damage by electrostatic discharges greater than or equal to 100 V human body model (HBM).
RoHS	Restriction of Hazardous Substances Directive 2011/65/EU & 2015/863/EU
REACH	Regulation (EC) No 1907/2006 - Registration, Evaluation, Authorisation and Restriction of Chemicals EC1907/2006

Product Drawing

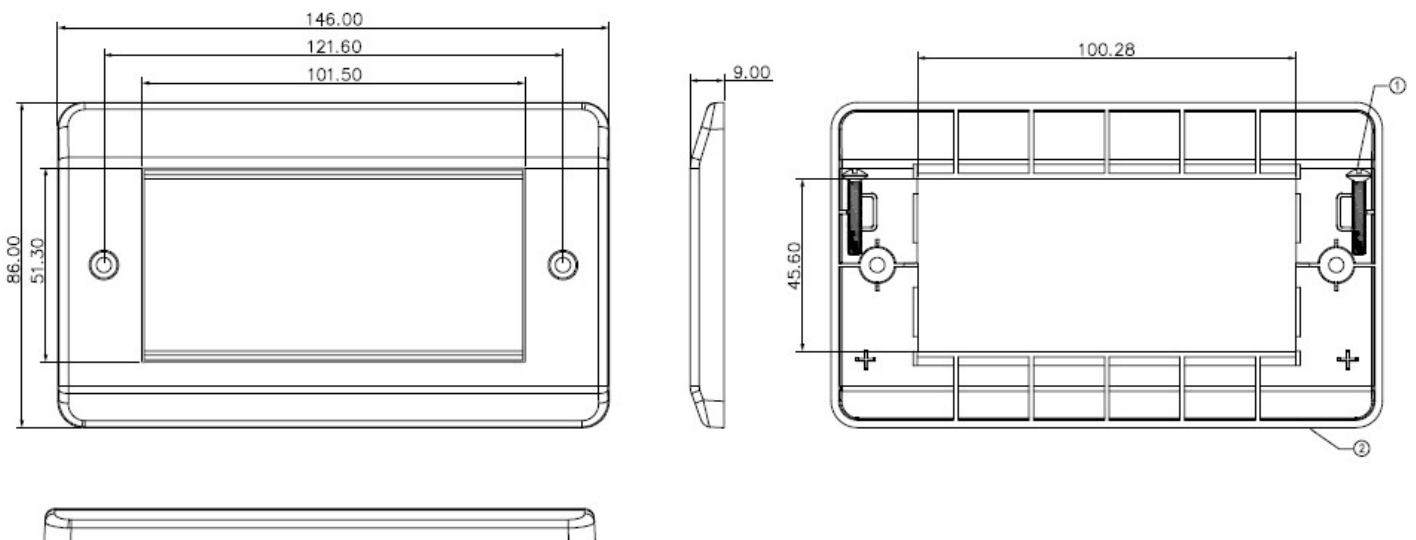

© PRYSMIAN GROUP 2020, All Rights Reserved

All sizes and values without tolerances are reference values. Specifications are for product as supplied by Prysmian: any modification or alteration afterwards of product may give different result.

The information contained within this document must not be copied, reprinted or reproduced in any form, either wholly or in part, without the written consent of Prysmian. The information is believed to be correct at the time of issue. Prysmian reserves the right to amend this specification without prior notice. This specification is not contractually valid unless specifically authorised by Prysmian.