

Draka UC Connectivity

Draka Flat Shutter for Keystone Jacks 25mm x 50mm - White

Part Number - YAABP03114

Overview

- Plastic Free Eco-Packaging – Pack of 24
- Mounts Draka keystone jacks into faceplates and floor boxes
- Compatible with all Draka UC keystone jacks
- Labelling field with clear protective cover
- Snap fit

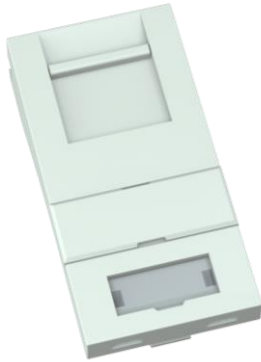

Product Description

Draka Flat Shutter fits the standard 25mm x 50mm Euro size type opening on Draka UC faceplates and are compatible with all the keystone jacks in the Draka UC portfolio. The adaptor has a spring-loaded shutter to protect the RJ45 port when not connected with a patch cord and comes with write-on label with clear protective window for port identification.

Draka Shutters are available in Angled Euromod 25mm x 50mm and 6C (LJ6C) 25mm x 38mm sizes. Blanking plates are available in half and quarter size for Euromod 25mm x 50mm size to configure single or triple outlets.

Product Specification

Angled Adapter Material	Plastic ABS, UL94HB
Temperature Range	-10°C to 60°C
Colour	White RAL 9003
Fastening	Engage (snap)
Surface	Flat
Width	25mm
Height	50mm

© PRYSMIAN GROUP 2020, All Rights Reserved

All sizes and values without tolerances are reference values. Specifications are for product as supplied by Prysmian: any modification or alteration afterwards of product may give different result.

The information contained within this document must not be copied, reprinted or reproduced in any form, either wholly or in part, without the written consent of Prysmian. The information is believed to be correct at the time of issue. Prysmian reserves the right to amend this specification without prior notice. This specification is not contractually valid unless specifically authorised by Prysmian.

Standards Complied

BSEN 60670-1:2005 + A1:2013	Boxes and enclosures for electrical accessories for household and similar fixed electrical installations general requirements
BSEN 61340-5-1:2007	Protection of electronic devices from electrostatic phenomena. General requirements apply to activities that: manufacture, process, assemble, install, package, label, service, test, inspect, transport or otherwise handle electrical or electronic parts, assemblies and equipment susceptible to damage by electrostatic discharges greater than or equal to 100 V human body model (HBM).
RoHS	Restriction of Hazardous Substances Directive 2011/65/EU & 2015/863/EU
REACH	Regulation (EC) No 1907/2006 - Registration, Evaluation, Authorisation and Restriction of Chemicals EC1907/2006

© PRYSMIAN GROUP 2020, All Rights Reserved

All sizes and values without tolerances are reference values. Specifications are for product as supplied by Prysmian: any modification or alteration afterwards of product may give different result.

The information contained within this document must not be copied, reprinted or reproduced in any form, either wholly or in part, without the written consent of Prysmian. The information is believed to be correct at the time of issue. Prysmian reserves the right to amend this specification without prior notice. This specification is not contractually valid unless specifically authorised by Prysmian.

Product Drawing

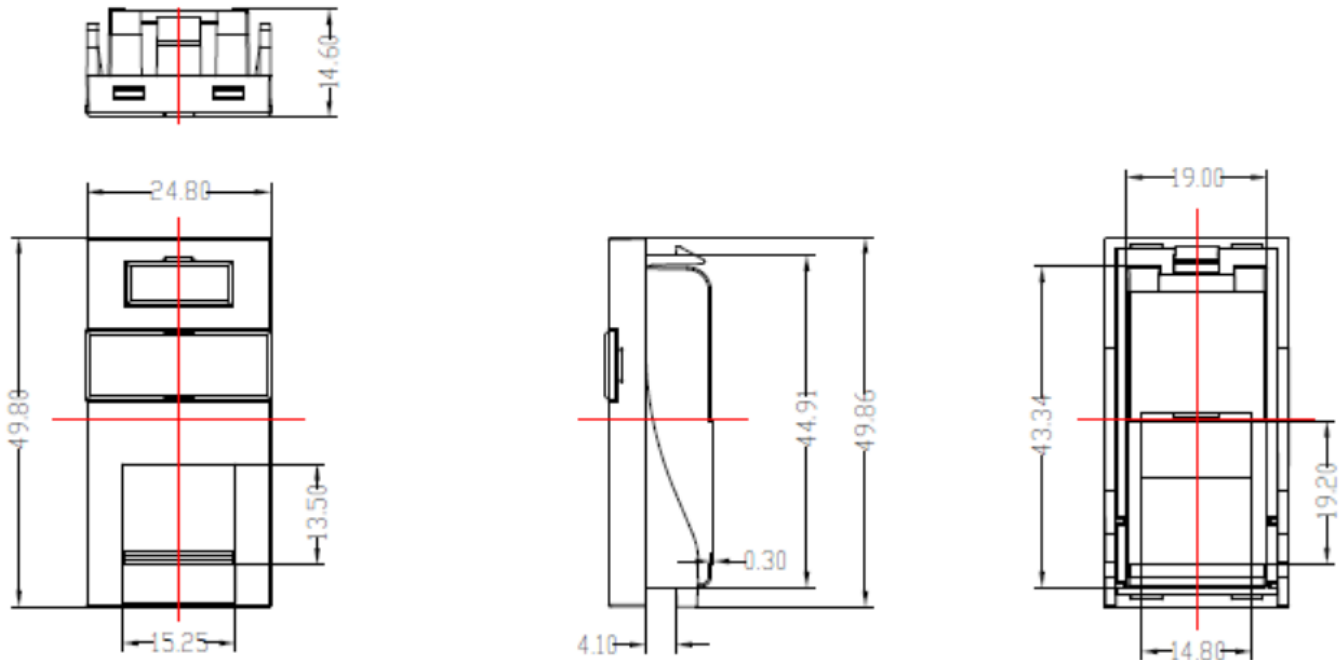

© PRYSMIAN GROUP 2020, All Rights Reserved

All sizes and values without tolerances are reference values. Specifications are for product as supplied by Prysmian: any modification or alteration afterwards of product may give different result.

The information contained within this document must not be copied, reprinted or reproduced in any form, either wholly or in part, without the written consent of Prysmian. The information is believed to be correct at the time of issue. Prysmian reserves the right to amend this specification without prior notice. This specification is not contractually valid unless specifically authorised by Prysmian.