

## MECH SEAL – 8 WAY GLAND INSTALLATION GUIDE

### KIT CONTENTS

ITEM No.:	DESCRIPTION	QTY
1	MEDIUM BODY SEALING GLAND	x1
2	MEDIUM NUT	x1
3	O-RING BS124 NITRILE	x2
4	STRENGTH MEMBER RETENTION BRACKET	x1
5	8-WAY GRIP PLATE	x1
6	M4 x 12mm CSK POZI PAN SCREW	x1
7	8-WAY CABLE SEAL	x1
8	8-WAY SPACER	x1
9	8-WAY SEAL PIN	x1
10	8-WAY x8 BLANKS ON SPRUE	x1
11	GREASE SACHET	x1

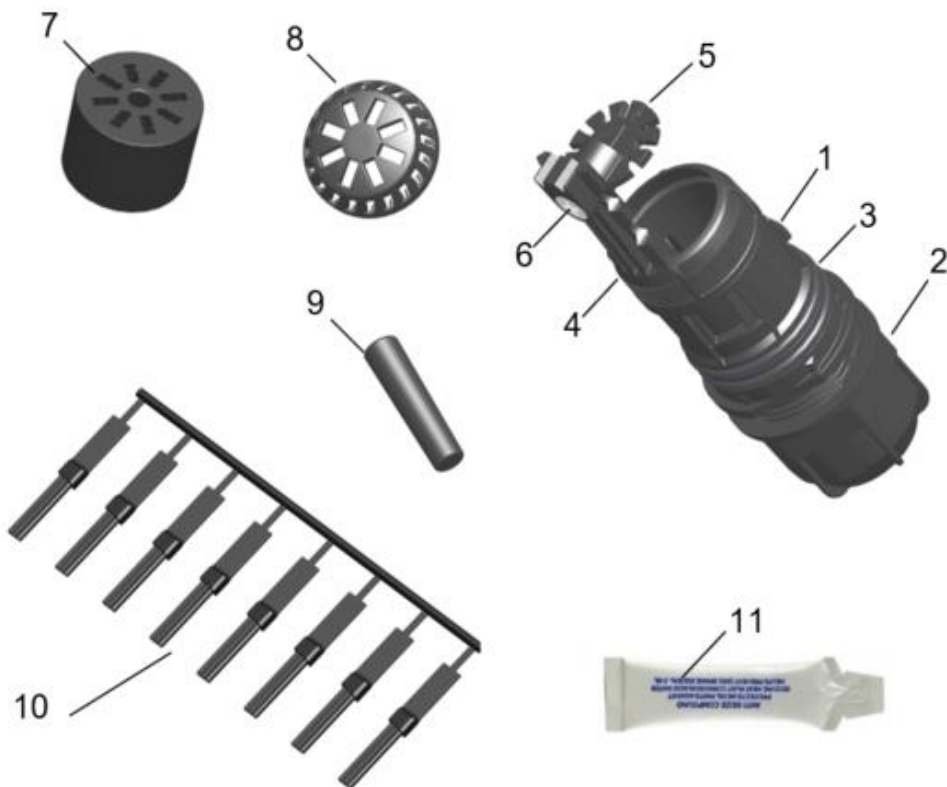

## MECH SEAL – 8 WAY GLAND INSTALLATION GUIDE

### Step 1

REMOVE PORT BLANK FROM BASE BY FULLY SQUEEZING TOGETHER THE TABS FROM INSIDE THE BASE.

**NOTE: YOU MAY NEED TO ROTATE THE BLANK IN THE PORT TO SQUEEZE THE TABS.**

USING YOUR OTHER HAND OR PLIERS, HOLD THE CENTRAL RIB AND FIRMLY PULL UNTIL THE PORT BLANK IS RELEASED.



## MECH SEAL – 8 WAY GLAND INSTALLATION GUIDE

### Step 2

INSERT THE SEAL PIN (9) INTO THE CENTRAL HOLE OF THE SEAL (7), THEN INSERT THE ASSEMBLY INTO THE GLAND ASSEMBLY (1) AS SHOWN.

NOTE: ENSURE THE PIN IS INSERTED SMALL DIAMETER END FIRST.



## MECH SEAL – 8 WAY GLAND INSTALLATION GUIDE

### Step 3

PUSH THE 8-WAY SPACER (8) ONTO THE SEAL ENSURING THE SLOTS IN THE SEAL AND SPACER LINE UP. APPLY SILICON GREASE (11) ONTO THE INSIDE THREADED AREA OF THE MEDIUM NUT (2) AND LOSELY FIT THE MEDIUM NUT (2) ONTO THE BODY.



## MECH SEAL – 8 WAY GLAND INSTALLATION GUIDE

### Step 4

APPLY SILICON GREASE (11) (SEE FIG 4.1) TO THE END OF THE FLAT DROP CABLE AND PUSH THE CABLE THROUGH ONE OF THE HOLES IN THE CABLE SEAL (7) (SEE FIG 4.2).

ENSURE THE CATENARY WIRE IS LOCATED IN THE OUTSIDE DIAMETER OF THE SEAL. FIRMLY PUSH THROUGH THE BREAK-OUT LAYER, FEED THE CABLE THROUGH APPROX. 1700mm.

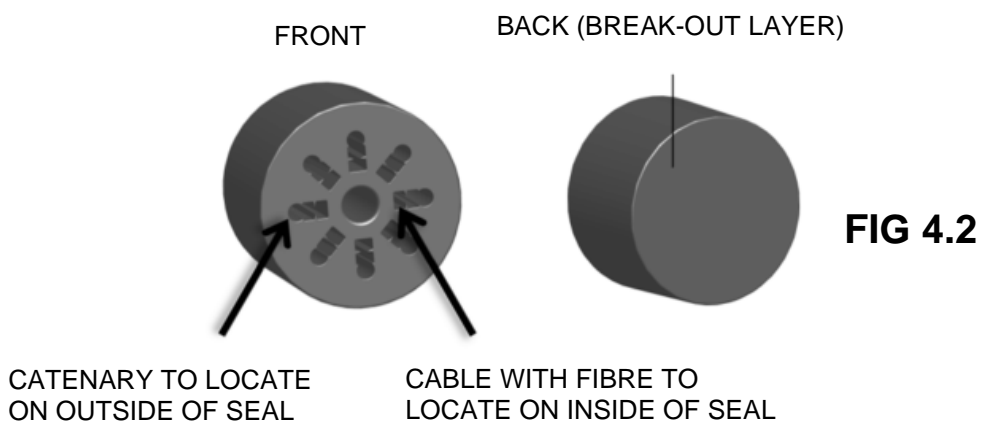
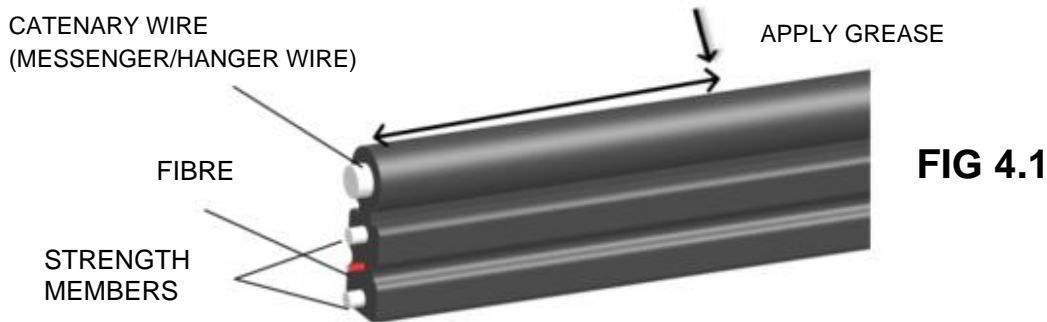

## MECH SEAL – 8 WAY GLAND INSTALLATION GUIDE

### Step 5

MEASURE BACK 1610mm ALONG THE FLAT DROP CABLE AND IDENTIFY THE CATENARY WIRE (MESSENGER/HANGER WIRE) (FIG 5.1). STRIP THE CATENARY WIRE BACK 1610mm THEN APPLY 100mm OF GREASE (11) TO THE CABLE(S) AROUND THE FULL CIRCUMFERENCE USING YOUR FINGER 100mm BACK FROM THE CABLE BUTT AND PULL BACK INTO PLACE.

CHECK THE CATENARY WIRE IS LOCATED ON THE OUTSIDE, AND SNIP THE CATENARY WIRE FLAT. BE CAREFUL TO ENSURE ALL THE EDGES HAVE BEEN REMOVED AND POSITION IN LINE WITH THE BRACKET EDGE (FIG 5.2).

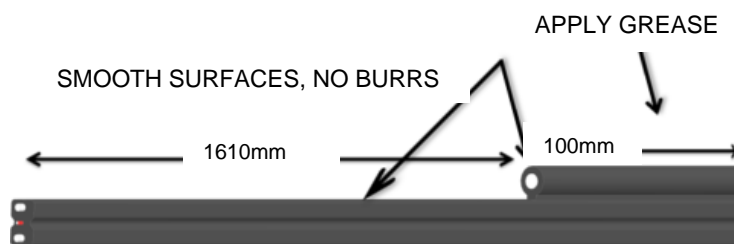

**FIG 5.1**

CATENARY TO TERMINATE IN LINE WITH BRACKET EDGE AND FACING OUTSIDE DIAMETER.

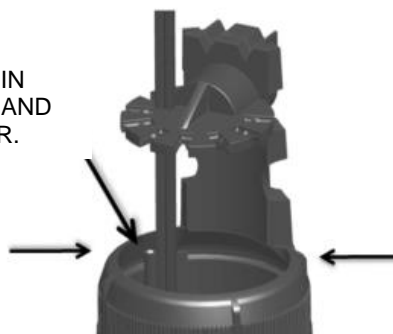
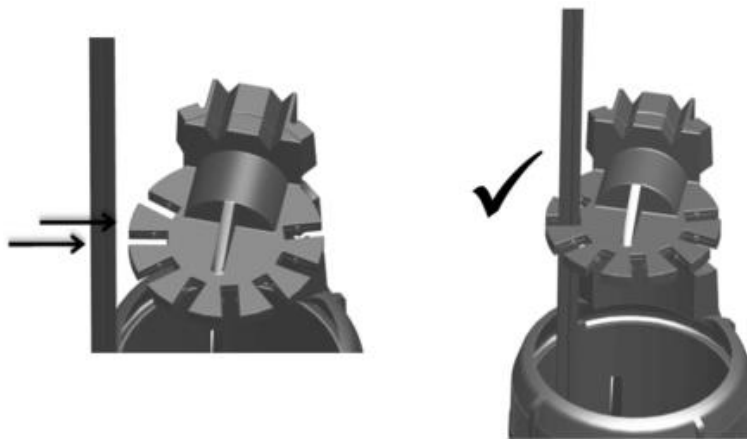

**FIG 5.2**

## MECH SEAL – 8 WAY GLAND INSTALLATION GUIDE

### Step 6

LINE THE CABLE UP WITH THE NEAREST CABLE GRIP POSITION IN THE 8-WAY GRIP PLATE (5). PUSH THE CABLE INTO THE GRIP TO SECURE. LIGHTLY PULL ON THE CABLE TO TEST THE CABLE HAS BEEN PUSHED IN FULLY.



## MECH SEAL – 8 WAY GLAND INSTALLATION GUIDE

### Step 7

REPEAT STEP 4 TO 5 AS MANY TIMES AS NECESSARY TO ADD ALL ADDITIONAL CABLES. REMOVE ENOUGH BLANKS FROM THE SPRUE (10) TO POPULATE ALL REMAINING CABLE SLOTS. ENSURE BLANK IS INSERTED CORRECTLY, IT HAS THE SAME PROFILE AS CABLE. AND FINALLY TIGHTEN THE MEDIUM NUT (2) DOWN TO THE BASE OF THE THREAD USING ADDITIONAL ITEM SPANNER (XJTSC02320 USER GUIDE IP460).

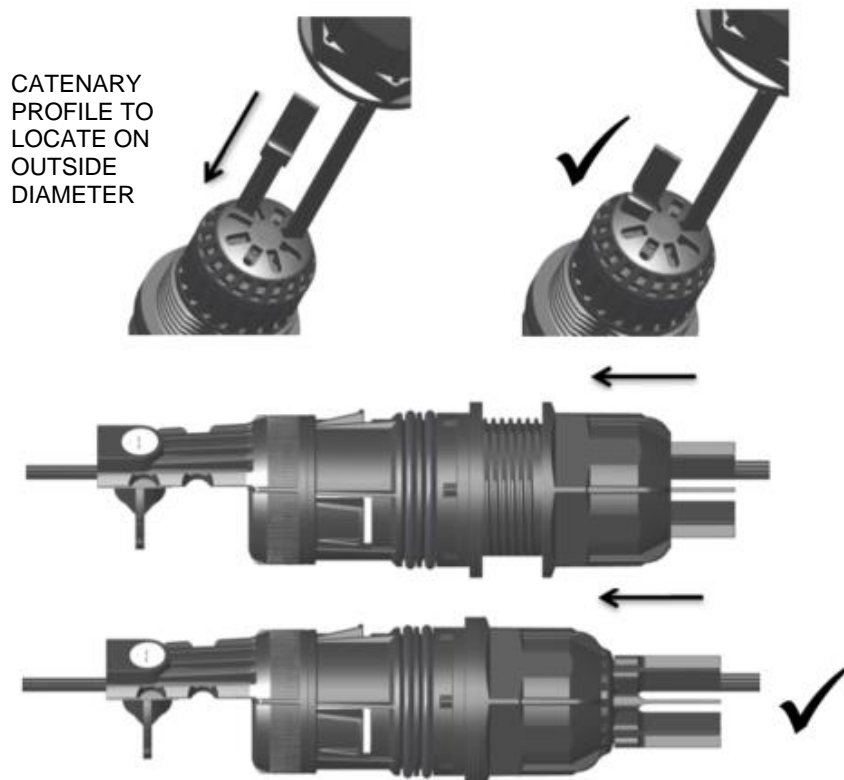



## MECH SEAL – 8 WAY GLAND INSTALLATION GUIDE

### Step 8

PUSH GLAND (1) INTO CMJ BASE. ONCE RESISTANCE ON O-RING IS FELT, CONTINUE PUSHING WITH A TWISTING ACTION UNTIL AN AUDIBLE CLICK IS HEARD. VISUALLY CHECK FROM INSIDE THE BASE ALL 3 CLIPS ARE SECURED INTO BASE.

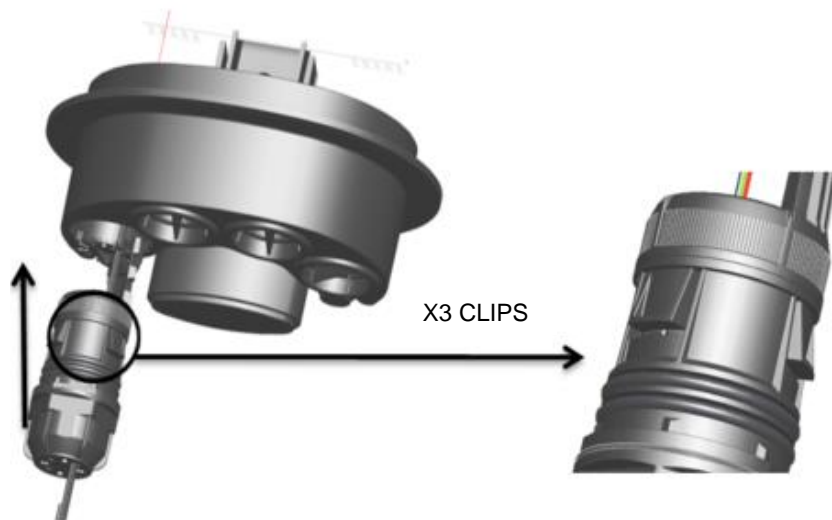

## MECH SEAL – 8 WAY GLAND INSTALLATION GUIDE

### Step 9

EXPOSE THE FIBRE BY STRIPING THE SHEATH BACK 1500mm. THIS WILL LEAVE APPROX 110mm OF DROP CABLE SHEATH REMAINING.

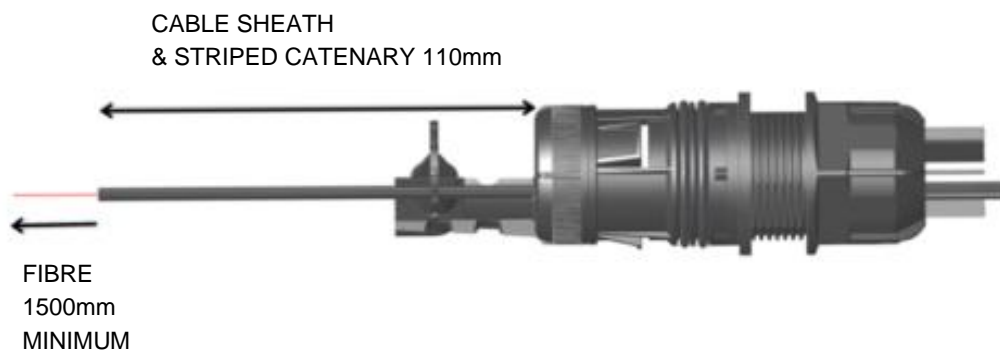

## MECH SEAL – 8 WAY GLAND INSTALLATION GUIDE

### Step 10

INSERT THE FLAT DROP CABLE INTO THE MANIFOLD RESTRAINT AND ENSURE THE SHEATH ALIGNS AT THE INDICATED POSITION, AS SHOWN. ROUTE ELEMENTS AND FIBRES AS PER THE CLOSURE INSTALLATION INSTRUCTIONS.

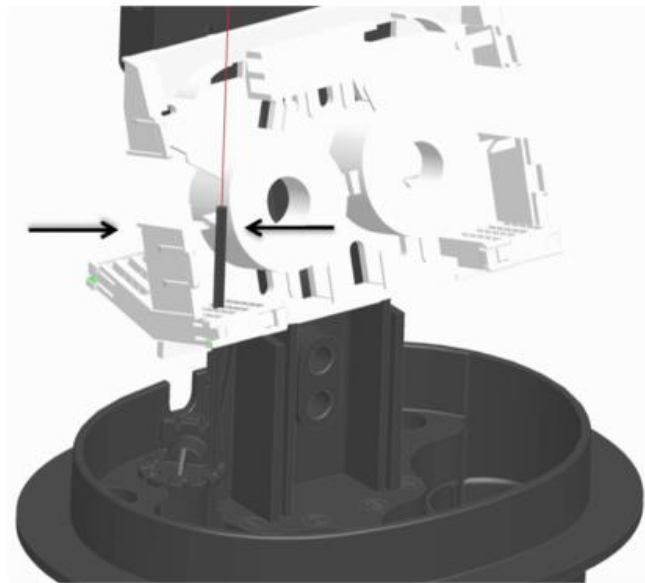

## MECH SEAL – 8 WAY GLAND INSTALLATION GUIDE

### Step 11

#### ADDITIONAL CABLE INSTALLTION

TO INSTALL ADDITIONAL CABLES, LOOSEN THE MEDIUM NUT (2) USING ADDITIONAL ITEM SPANNER (XJTSC02320 USER GUIDE IP460). AND REMOVE SAME NUMBER OF BLANKS (10) TO NEW INSTALLED CABLES.



## MECH SEAL – 8 WAY GLAND INSTALLATION GUIDE

### Step 12

#### ADDITIONAL CABLE INSTALLTION

FOLLOW CABLE PREPERATION STEPS 3 TO 5. TIGHTEN THE MEDIUM NUT DOWN TO THE BASE OF THE THREAD USING ADDITIONAL ITEM SPANNER (XJTSC02320 USER GUIDE IP460).

STRIP THE CABLE FOLLOWING STEP 7 AND ROUTE THE FIBRE BY FOLLOWING STEP 9 TO FINISH.