

TUBE DISTRIBUTION CLOSURE (XBFSC00215) INSTALLATION GUIDE

KIT CONTENTS

ITEM No.:	DESCRIPTION	QTY
1	TDC COVER ASSEMBLY	x1
2	TDC BASE	x1
3	IN-LINE CLAMP ASSEMBLY	x2
4	FOAM CORD 4.5mm DIAMETER (not shown)	x2
5	BUTYL RUBBER STRIP 450mm (not shown)	x2
6	SPLIT GLAND LOWER	x2
7	SPLIT GLAND UPPER	x2
8	GLAND FILLER	x2
9	INSTALLATION GUIDE	x1
10	SCREW No.10 x 1" SS POZI PAN HEAD	x4

ADDITIONAL ACCESSORIES:

DESCRIPTION

TDC INSTALLATION TOOL	TDC GLAND SPANNER
GLAND INSTALLATION TOOL	TDC KNOCKOUT TOOL KIT
SILICONE GREASE	SILICONE GREASE

NOTE: FOR MORE DETAILED INSTALLATION INSTRUCTIONS REFER TO CIG057

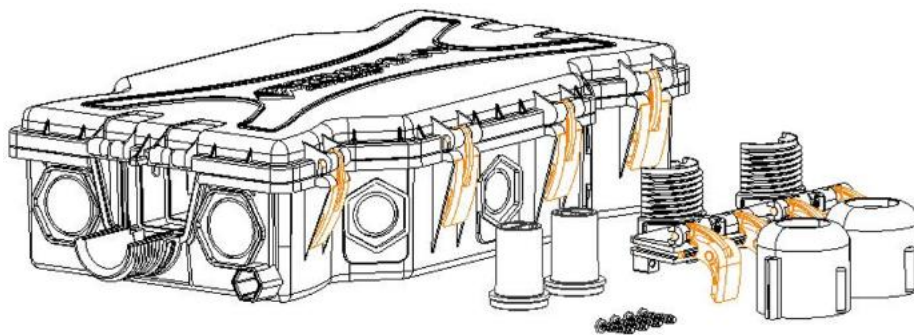

TUBE DISTRIBUTION CLOSURE (XBFSC00215) INSTALLATION GUIDE

Step 1



WARNING: The Tube Distribution Closure is a sealed closure used for blown applications. For safety reasons it is necessary that the pressure relief valve fitted in the bottom corner of the unit is pulled, before opening the closure, to ensure that there is no residual pressure within the closure.

ENSURE THE VALVE RECESS IS CLEAN AND FREE OF DEBRIS.
WITH A PAIR OF LONG NOSE PLIERS PULL THE VALVE TO RELEASE
PRESSURE!

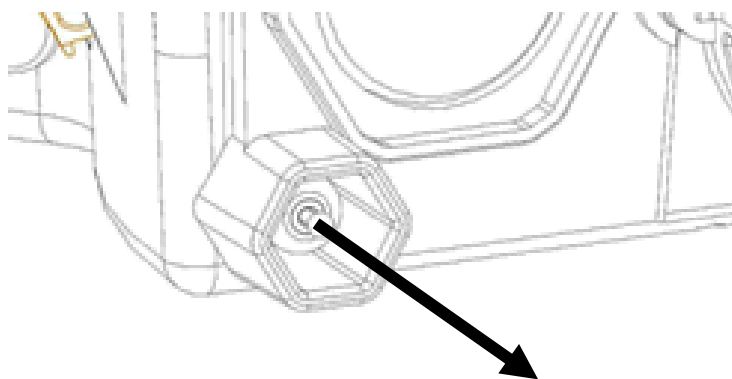

TUBE DISTRIBUTION CLOSURE (XBFSC00215) INSTALLATION GUIDE

Step 2

TAKE THE COVER OFF THE TDC OBSERVING THE SAFETY PRACTICES IN STEP 1. TO DO THIS RELEASE THE 8 ORANGE TOGGLE LATCHES AROUND THE OUTSIDE.

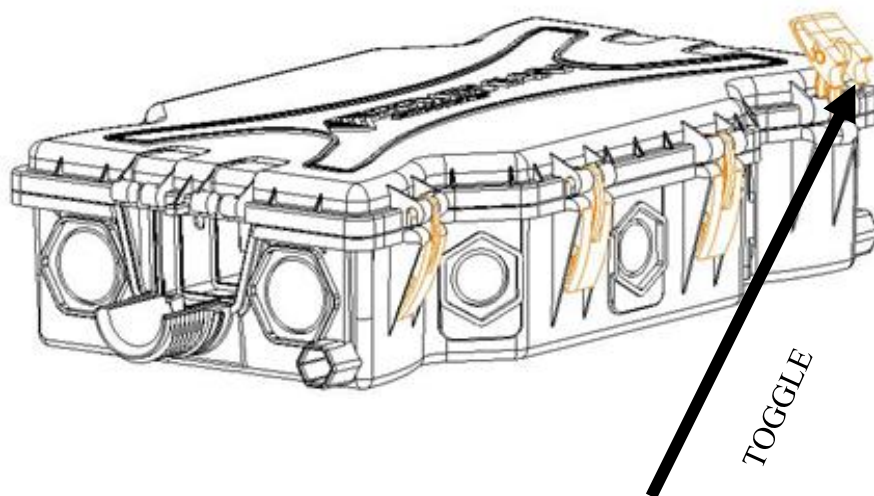

TUBE DISTRIBUTION CLOSURE (XBFSC00215) INSTALLATION GUIDE

Step 3

APPLY SILICONE GREASE TO THE FOAM CORD. INSERT THE GREASED FOAM CORD INTO THE SLOT ON THE IN-LINE CLAMP AND MAKING SURE NOT TO STRETCH IT DURING APPLICATION. FIRMLY PUSH INTO POSITION ENSURING THE CORD IS WELL INTO THE GROOVE.

THE END OF THE CORD SHOULD BE PROUD OF THE SEALING RIB (2mm MAX)

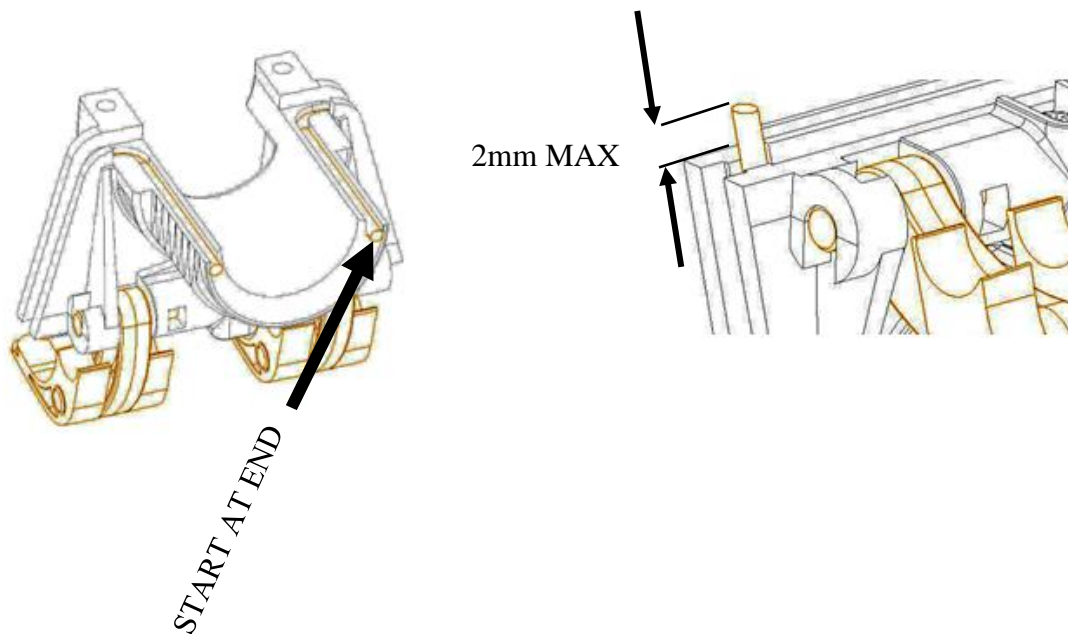

TUBE DISTRIBUTION CLOSURE (XBFSC00215) INSTALLATION GUIDE

Step 4

FOR DIRECT BURY CABLES REMOVE A 650mm WINDOW OF THE OUTER SHEATH, THEN REMOVE A 350mm WINDOW OF THE INNER SHEATH IN THE CENTRE OF THE EXPOSED WINDOW. POSITION THE TDC BASE AROUND THE CABLE AND USING 2 OF THE No.10 x 1" SCREWS FIT THE INLINE CLAMP ASSEMBLIES AS SHOWN.

LAY THE CABLE IN THE CHANNELS AT EITHER END OF THE TDC BASE AND THEN SLIDE THE IN-LINE CLAMPS INTO EACH END OF THE TDC BASE MAKING SURE THE FOAM CORD SEALS ARE IN POSITION AND FIX WITH THE 4 SCREWS.

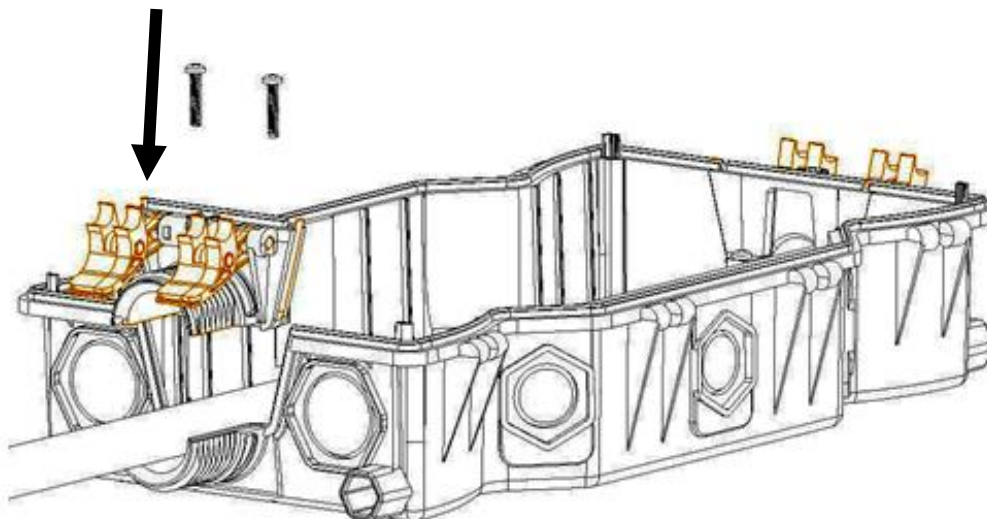

TUBE DISTRIBUTION CLOSURE (XBFSC00215) INSTALLATION GUIDE

Step 5

TAKE THE BUTYL RUBBER STRIP AND PEEL OFF A SHORT AMOUNT OF THE BACKING. WRAP THE BUTYL STRIP AROUND THE CABLE MAKING SURE THAT THE STRIP IS PUSHED FIRMLY ONTO THE CABLE AND THAT IT IS NOT STRETCHED DURING APPLICATION. BUILD THE BUTYL STRIP UP UNTIL IT IS JUST BELOW THE THREAD.

NOTE: THE STRIP MUST BE AS CLOSE TO THE END OF THE THREAD AS POSSIBLE.

NOW WRAP YOUR SELECTED SPLIT RUBBER GLAND (SOLD SEPARATELY) BEHIND THE BUTYL RUBBER RING SO THE LARGE FLAT FACE IS JUST TOUCHING ON THE BUTYL RUBBER.

APPLY SOME SILICONE GREASE (SOLD SEPARATELY) TO THE HATCHED SURFACES.

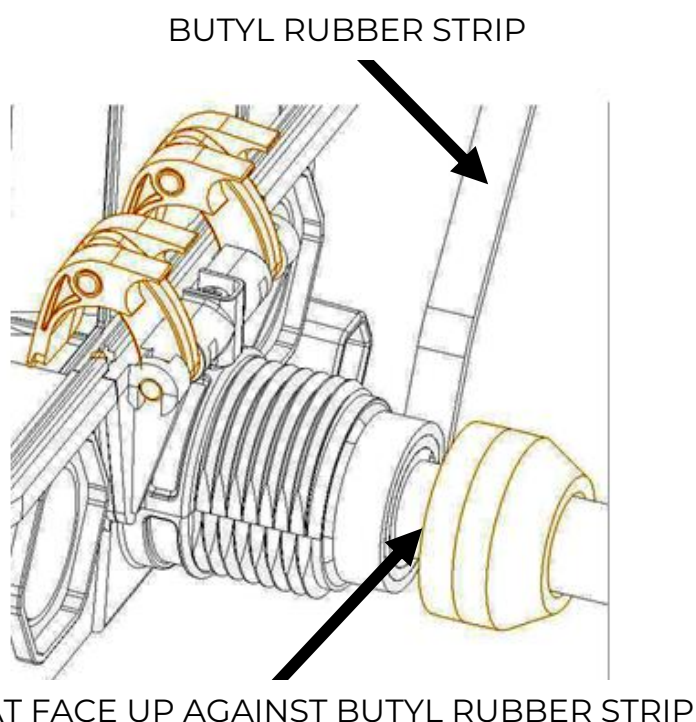

TUBE DISTRIBUTION CLOSURE (XBFSC00215) INSTALLATION GUIDE

Step 6

SLIDE BOTH OF THE SPLIT GLANDS APART.

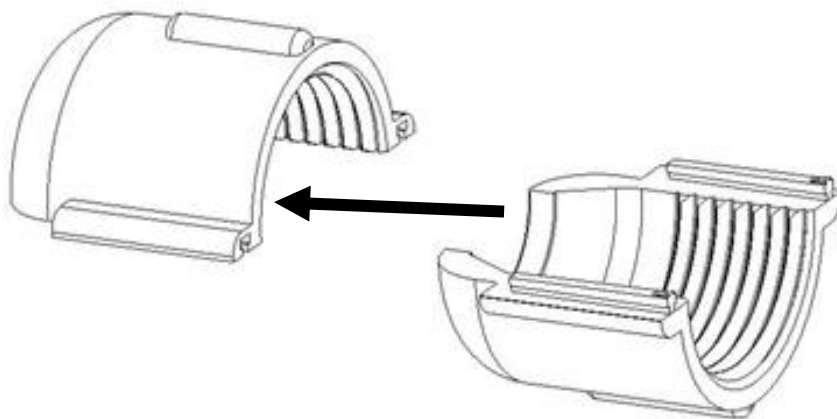

TUBE DISTRIBUTION CLOSURE (XBFSC00215) INSTALLATION GUIDE

Step 7

REASSEMBLE THE SPLIT GLAND AROUND THE CABLE. REPEAT AT BOTH ENDS.

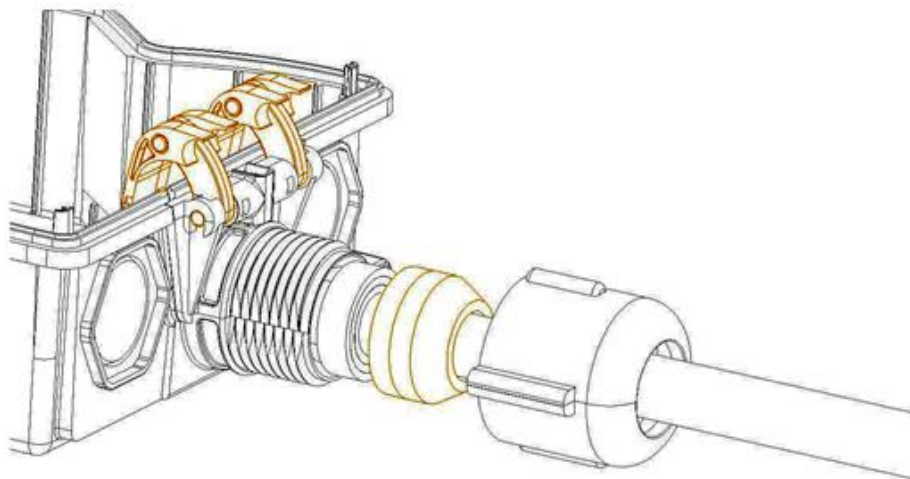

TUBE DISTRIBUTION CLOSURE (XBFSC00215) INSTALLATION GUIDE

Step 8

TIGHTEN BOTH OF THE ASSEMBLED SPLIT GLANDS TO THE TDC ASSEMBLY AND FULLY TIGHTEN.

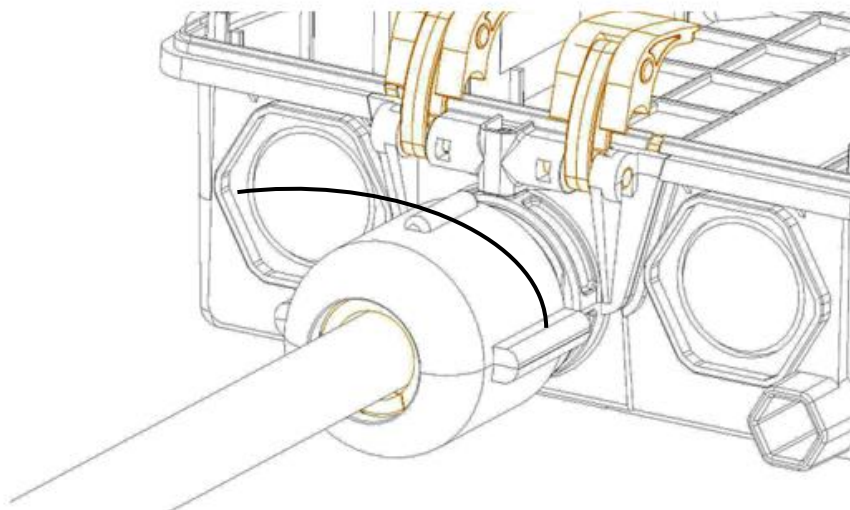

TUBE DISTRIBUTION CLOSURE (XBFSC00215) INSTALLATION GUIDE

Step 9

ENSURE THE SEAL IN THE LID AND THE TDC SEALING EDGE IS CLEAR FROM DEBRIS PLACE THE COVER CAREFULLY OVER THE TDC BASE UNIT AND FIX IN POSITION USING THE TOGGLE LATCHES.