

MECH SEAL – BF TUBE INSTALLATION GUIDE

KIT CONTENTS

ITEM No.:	DESCRIPTION	QTY
1	MEDIUM BODY SEALING GLAND	x1
2	MEDIUM NUT	x1
3	O-RING BS124 NITRILE	x2
4	FLEXICON CONDUIT SEAL	x1
5	INTERSTICES SEAL	x1
6	INTERSTICES NUT	x1
7	INTERSTICES SPREADER	x1
8	INTERSTICES COMPRESSION WASHER	x1



USING THE TABLE BELOW IDENTIFY THE CORRECT INTERSTICES ASSEMBLY FOR THE CABLE YOU ARE INSTALLING BASED ON TUBE DIAMETER AND NO. OF TUBES.

TUBE \varnothing	KIT PART NO.	INTERSTICES SEAL	INTERSTICES SPREADER	INTERSTICES WASHER
5mm	XJTSC01764	4 TUBES	4 TUBES	4 TUBES
	XJTSC02008	7 TUBES	7 TUBES	7 TUBES
6mm	XJTSC01791	4 TUBES	4 TUBES	4 TUBES
	XJTSC02009	7 TUBES	7 TUBES	7 TUBES

MECH SEAL – BF TUBE INSTALLATION GUIDE

Step 1

THE MECHANICAL GLAND SYSTEM IS DESIGNED FOR USE WITH 25mm FLEXIBLE CONDUIT FOR REDUCED CABLE BEND RADIUS EXITING THE CLOSURE. THE SYSTEM IS USED TO INSTALL A BFT CABLE INTO A TUBE INTERCEPT JOINT (TIJ) OR A JOINT CLOSURE SUCH AS THE SMALL, MEDIUM, LARGE & EXTRA-LARGE TM NODE.

FOR TIJ INSTALLATION

IF THE TIJ AND ASSOCIATED JOINT IS CO-LOCATED WITHIN THE SAME JOINT BOX, USE A LENGTH OF BFT TO DETERMINE THE DISTANCE BETWEEN THE TWO ITEMS. INCREASE THIS LENGTH BY 500mm BEFORE CUTTING.

- REMOVE THE OUTER SHEATHING FROM THE BFT CABLE
- OVER SLEEVE THE INDIVIDUAL BFT TUBES WITH 25mm FLEXIBLE CONDUIT LEAVING APPROX 300mm EXPOSED TUBE AT THE TIJ END AND 200mm AT THE JOINT END.

IF THE TIJ AND JOINT ARE NOT CO-LOCATED, CONDUIT SHOULD STILL BE INSTALLED FOR THE FIRST METER EXITING THE TIJ.

- REMOVE APPROX 1.3m OUTER SHEATHING FROM THE BFT CABLE.
- OVER SLEEVE THE INDIVIDUAL TUBES WITH 1.0m OF CONDUIT AND TERMINATE TO THE CABLE SHEATH USING NORMAL PRACTICE.

GO TO STEP 3

MECH SEAL – BF TUBE INSTALLATION GUIDE

Step 2

FOR SMALL, MEDIUM, LARGE & EXTRA-LARGE TM NODE INSTALLATION

THE FLEXICON CONDUIT 25mm SHOULD STILL BE INSTALLED FOR THE FIRST TWO METERS EXITING THE UNIVERSAL NODE.

- REMOVE APPROX 2.2m OUTER SHEATHING FROM THE BFT CABLE.
- OVER SLEEVE THE INDIVIDUAL TUBES WITH 2.0m OF CONDUIT AND TERMINATE TO THE CABLE SHEATH USING NORMAL PRACTICE.



MECH SEAL – BF TUBE INSTALLATION GUIDE

Step 3

MARK OFF 1.2M OF THE 25mm FLEXIBLE CONDUIT. CUT THE CONDUIT USING BF CRIMPER/TUBE CUTTER. CLOSE THE TOOL AND ROTATE 360 DEGREES.



MECH SEAL – BF TUBE INSTALLATION GUIDE

Step 4

USING THE TABLE BELOW SELECT THE APPROPRIATE CONDUIT CONNECTOR FOR THE JOB.

ATTACH THE 25mm FLEXIBLE CONDUIT CONNECTOR TO THE BFT SHEATH AND TIGHTEN THE GLAND NUT BY HAND.

FEED THE FLEXIBLE CONDUIT ONTO THE EXPOSED TUBES AND PUSH INTO THE GLAND FITTING UNTIL IT LOCKS.

DESCRIPTION	USED WITH
7BFT (4.5/5mm) CONNECTOR FOR CONDUIT FLEXIBLE 25mm	7BFT 6mm
7BFT (2.74/4mm) CONNECTOR FOR CONDUIT FLEXIBLE 25mm x10	4BFT 5mm & 7BFT 4mm
4BFT (24.5/6mm) CONNECTOR FOR CONDUIT FLEXIBLE 25mm (BAG OF 10)	7BFT 5mm & 4BFT 6mm

MECH SEAL – BF TUBE INSTALLATION GUIDE

Step 5

FEED THE GLAND NUT OVER THE TUBES AND PARTIALLY DOWN THE CONDUIT. FEED THE RUBBER SEAL OVER THE END OF THE CONDUIT AS SHOWN BELOW. PUSH THE TUBES THROUGH THE GLAND BODY (1) & INTERSTICES SEAL (5, 6, 7 & 8). THE TUBES WILL BE GUIDED BY THE SPREADER (7) AND EVENLY PUSH THROUGH THE SEAL (5) AND WASHER (8).

LOCATE THE CONDUIT WITH THE SEAL ON THE END INTO THE GLAND AND PUSH AGAINST THE STOP. BRING THE GLAND NUT TOWARDS THE BODY AND TIGHTEN.

TIGHTEN THE INTERSTICES NUT TO SEAL AROUND THE TUBES.

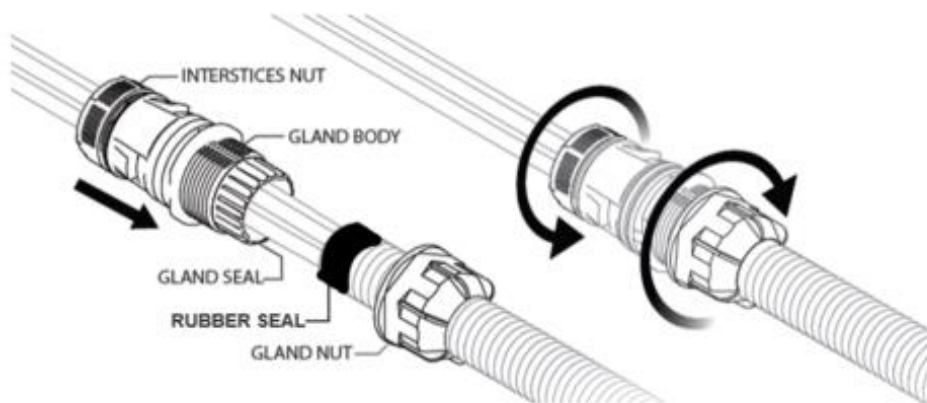

MECH SEAL – BF TUBE INSTALLATION GUIDE

Step 6

FOR TIJ INSTALLATION

SELECT A POSITION FOR THE DROP AND REMOVE THE PORT BLANK:

- NIP THE TWO RETAINING CLIPS TOGETHER FROM INSIDE THE TIJ ASSEMBLY.
- PUSH THE PORT BLANK OUT OF THE CLAMP FROM THE INSIDE
- THE PORT BLANK CAN BE DISCARDED.

NOTE: THE PORT BLANK CAN BE ROTATED FOR IMPROVED ACCESS TO THE RELEASE CLIPS. IF THE PORT BLANK IS DIFFICULT TO REMOVE, A SUITABLE PAIR OF PLIERS CAN BE USED TO GRIP THE CENTRAL WEB AND PULL THE BLANK CLEAR OF THE CLAMP.

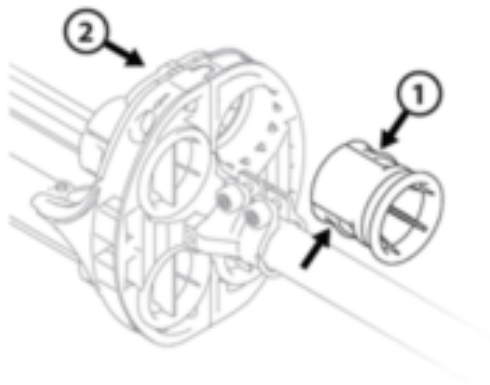

MECH SEAL – BF TUBE INSTALLATION GUIDE

Step 7

INSERT THE GLAND ASSEMBLY INTO THE PORT AND PUSH UNTIL IT CLIPS INTO POSITION. THE GLAND ASSEMBLY MAY NEED TO BE ROTATED SLIGHTLY TO LOCATE THE ANTI-ROTATION SPLINES.

NOTE: AN AUDIBLE CLICK SHOULD BE HEARD WHEN INSTALLING THE GLAND – PULL BACK ON THE GLAND ASSEMBLY TO ENSURE IT IS SECURELY FITTED.

REFER TO THE TIJ INSTRUCTIONS TO APPLY END CAPS TO EACH TUBE AND FOR BLOWN FIBRE CONNECTION AND ROUTING.

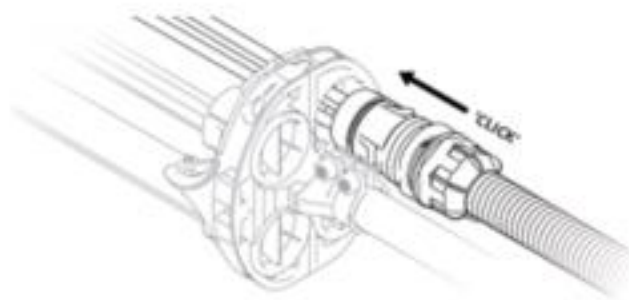

MECH SEAL – BF TUBE INSTALLATION GUIDE

Step 8

FOR SMALL, MEDIUM, LARGE & EXTRA-LARGE TM NODE INSTALLATION

REMOVE PORT BLANK FROM BASE BY FULLY SQUEEZING TOGETHER THE TABS FROM INSIDE THE BASE AND DISCARD.

NOTE: YOU MAY NEED TO ROTATE THE BLANK IN THE PORT TO SQUEEZE THE TABS.

USING YOUR OTHER HAND OR PLIERS HOLD THE CENTRAL RIB AND FIRMLY PULL UNTIL THE PORT BLANK IS RELEASED.

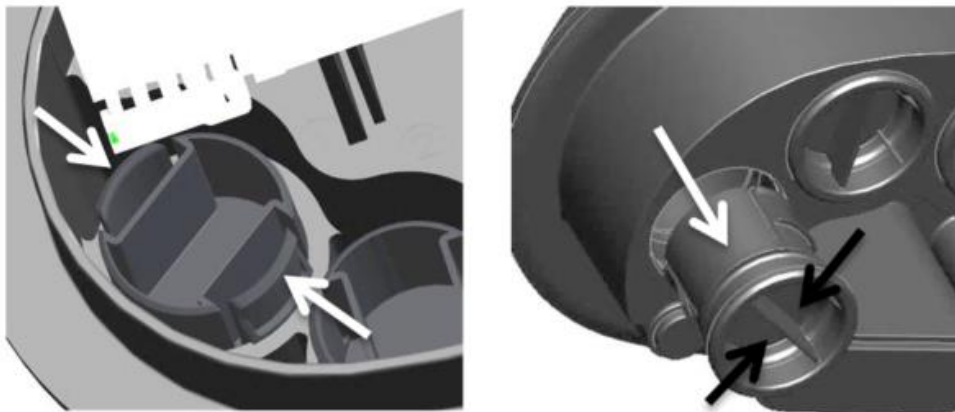

MECH SEAL – BF TUBE INSTALLATION GUIDE

Step 9

PUSH GLAND (1) INTO BASE. ONCE RESISTANCE ON O-RING IS FELT, CONTINUE PUSHING WITH A TWISTING ACTION UNTIL AN AUDIBLE CLICK IS HEARD. VISUALLY CHECK FROM INSIDE THE BASE ALL 3 CLIPS ARE SECURED INTO BASE. REFER TO THE JOINT DOCUMENT TO APPLY END CAPS TO EACH TUBE AND FOR BLOWN FIBRE ROUTING.

