

MECH SEAL – 8-WAY 2.4mm & 3.0mm CABLE INSTALLATION GUIDE

KIT CONTENTS

ITEM No.:	DESCRIPTION	QTY
1	MEDIUM BODY SEALING GLAND	x1
2	MEDIUM NUT	x1
3	O-RING BS124 NITRILE	x2
4	STRENGTH MEMBER RETENTION BRACKET	x1
5	8-WAY CIRCULAR GRIP PLAT	x1
6	M4 x 12mm CSK POZI PAN SCREW	x1
7	8-WAY CIRCULAR CABLE SEAL	x1
8	8-WAY SPACER	x1
9	8-WAY SEAL PIN	x1
10	8-WAY CIRCULAR x8 BLANKS ON SPRUE	x1
11	1mm SPACER	x3
12	ARAMID RETENTION BACKET	x1
13	ARAMIID RETENTION CLIP	x4
14	GREASE SACHET	x1

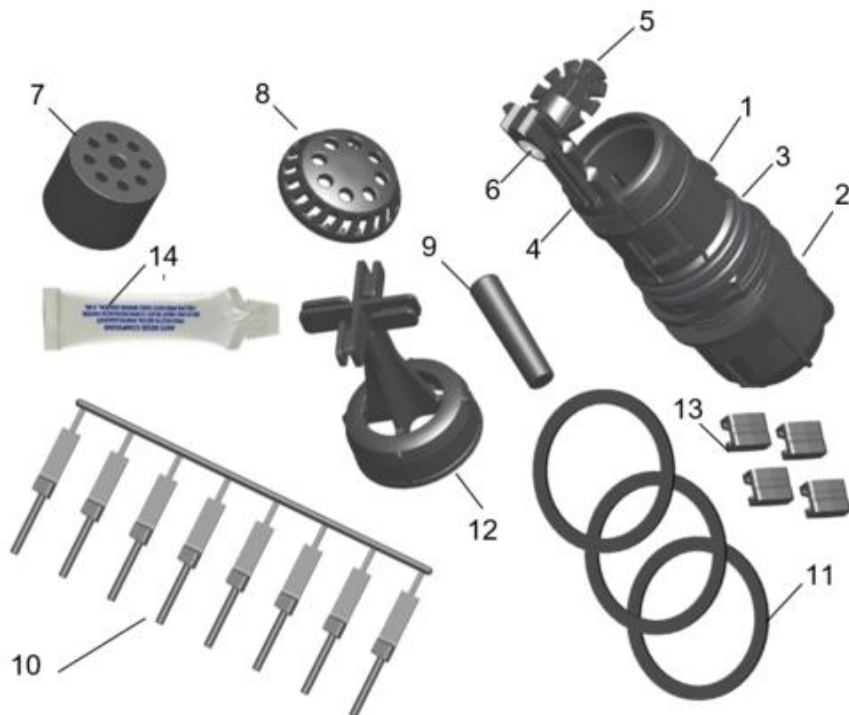

**MECH SEAL – 8-WAY 2.4mm &
3.0mm CABLE INSTALLATION GUIDE**

Step 1

REMOVE PORT BLANK FROM BASE BY FULLY SQUEEZING TOGETHER THE TABS FROM INSIDE THE BASE.

NOTE: YOU MAY NEED TO ROTATE THE BLANK IN THE PORT TO SQUEEZE THE TABS.

USING YOUR OTHER HAND OR PLIERS, HOLD THE CENTRAL RIB AND FIRMLY PULL UNTIL THE PORT BLANK IS RELEASED.



**MECH SEAL – 8-WAY 2.4mm &
3.0mm CABLE INSTALLATION GUIDE**

Step 2

IDENTIFY THE CABLE DIAMETER AND USING THE TABLE BELOW SELECT THE CORRECT NUMBER OF SPACERS REQUIRED.

CABLE Ø	SEAL SIZE (9)	CABLE RANGE	SPACERS (11)
2.4mm	SEAL XJTSG02139	2.4-2.6mm	2
3.0mm		3.0mm	3

**MECH SEAL – 8-WAY 2.4mm &
3.0mm CABLE INSTALLATION GUIDE**

Step 3

INSERT THE SEAL PIN (9) INTO THE CENTRAL HOLE OF THE SEAL (7), THEN INSERT THE ASSEMBLY INTO THE GLAND ASSEMBLY (1) AS SHOWN.



**MECH SEAL – 8-WAY 2.4mm &
3.0mm CABLE INSTALLATION GUIDE**

Step 4

THREAD THE SPACERS (11) IF REQUIRED, 8-WAY SPACER (8) AND MEDIUM NUT (2) ONTO THE CABLE. APPLY SILICON GREASE (14) TO THE CABLE/TUBE AND PUSH THE CABLE/TUBE THROUGH ONE OF THE HOLES IN THE CABLE SEAL (7). BEFORE LOOSELY FITTING MEDIUM NUT (2) ONTO MEDIUM BODY (1) APPLY SILICON GREASE (14) ONTO INSIDE THREADED AREA.

GO TO STEP 5 FOR BEND LIMITING TUBE INSTALLATION.

GO TO STEP 8 FOR 2.4mm & 3.0mm CABLE INSTALLATION.

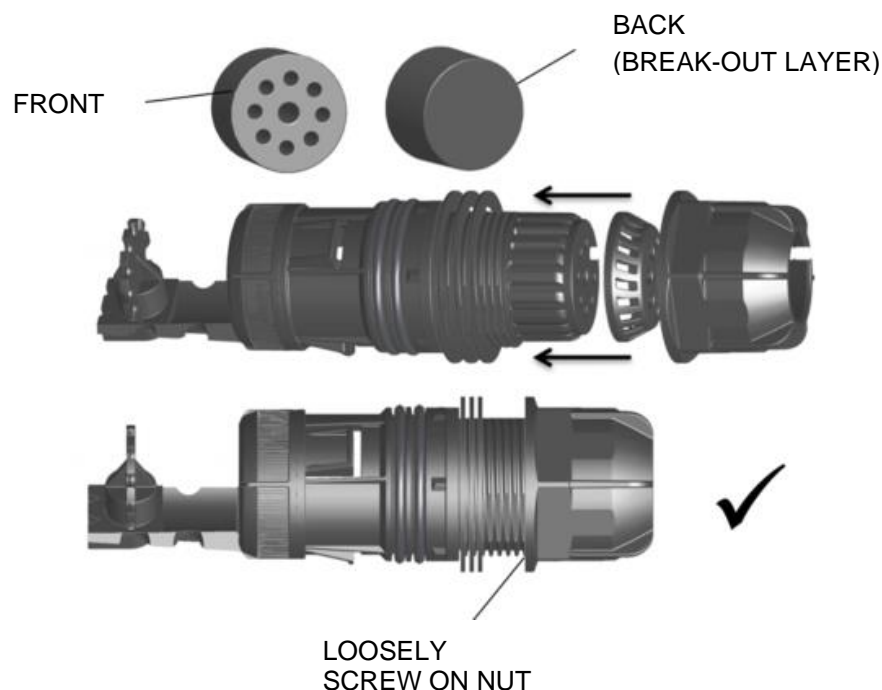

**MECH SEAL – 8-WAY 2.4mm &
3.0mm CABLE INSTALLATION GUIDE**

Step 5

LOCATE THE BEND LIMITING TUBE.

BE CAREFUL TO ENSURE ALL THE EDGES HAVE BEEN REMOVED SO THE BEND LIMITING TUBE IS SMOOTH READY TO BE PUSHED THROUGH THE SEAL.

FIRMLY PUSH THROUGH THE BREAK-OUT LAYER, FEED THE TUBE THROUGH UNTIL THE TUBE PASSES THE GRIP PLATE XXmm, AS BELOW. LOOSELY SCREW ON THE MEDIUM NUT (2).

NOTE: ENSURE THE CABLE SLOT OF THE SEAL (7) AND SPACER (8) LINE UP BEFORE INSERTING CABLE.

SMOOTH EDGES,
NO BURRS.

GROOVES WHICH
WILL LATER CLIP
INTO THE GRIP
PLATE

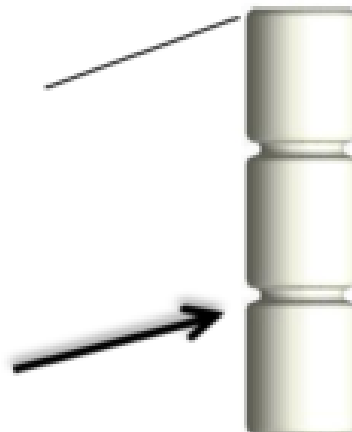

**MECH SEAL – 8-WAY 2.4mm &
3.0mm CABLE INSTALLATION GUIDE**

Step 6

LINE THE TUBE UP WITH THE NEAREST CABLE GRIP POSITION IN THE 8-WAY GRIP PLATE (5). PUSH THE CABLE INTO THE GRIP TO SECURE. LIGHTLY PULL ON THE CABLE TO TEST THE CABLE HAS BEEN PUSHED IN FULLY.

NOTE: LOCATE THE GROOVE OF THE TUBE INTO THE GRIP PLATE SLOT.

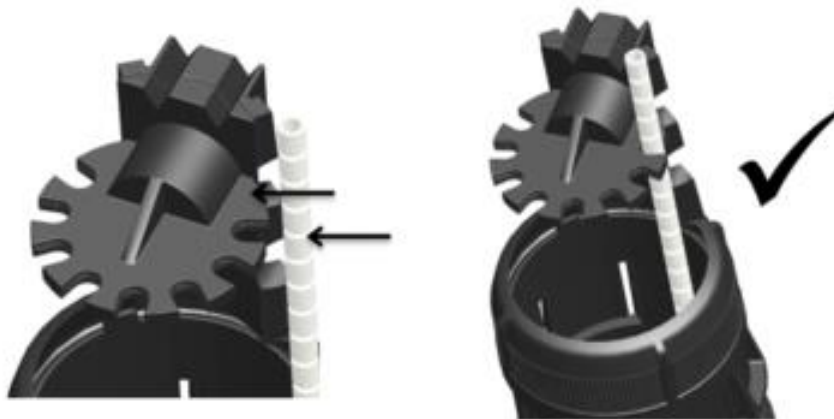

**MECH SEAL – 8-WAY 2.4mm &
3.0mm CABLE INSTALLATION GUIDE**

Step 7

REPEAT STEP 4 TO 5 AS MANY TIMES AS NECESSARY TO ADD ALL ADDITIONAL TUBES REQUIRED. REMOVE ENOUGH BLANKS FROM THE SPRUE (10) TO POPULATE ALL REMAINING CABLE SLOTS. ENSURE BLANK IS INSERTED CORRECTLY, IT HAS THE SAME PROFILE AS CABLE.

GO TO STEP 12.



**MECH SEAL – 8-WAY 2.4mm &
3.0mm CABLE INSTALLATION GUIDE**

Step 8

REMOVE STRENGTH MEMBER RETENTION BRACKET (4) AND REPLACE WITH ARAMID RETENTION BRACKET (12).

PUSH THROUGH APPROX 2.2m OF 2.4mm OR 3.0mm DIAMETER CABLE INTO THE SEAL. FIRMLY PUSH THROUGH THE BREAK-OUT LAYER, LOOSELY SCREW ON THE MEDIUM NUT (2).

NOTE: ENSURE THE CABLE SLOT OF THE SEAL (7) AND SPACER (8) LINE UP BEFORE INSERTING CABLE.

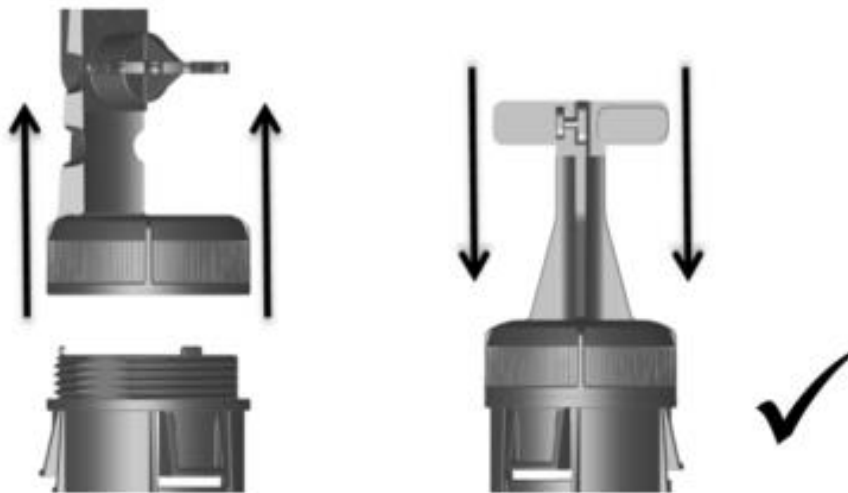

**MECH SEAL – 8-WAY 2.4mm &
3.0mm CABLE INSTALLATION GUIDE**

Step 9

STRIP CABLE BACK 2m (CMJ, MMJ) or 3m (LMJ) EXPOSING THE ELEMENTS, GRP AND ARAMID YARN IF APPLICABLE.

MEASURE FROM THE CABLE BUTT AND CUT THE ARAMID YARN TO 170mm. APPLY GREASE (14) ALONG CABLE SHEATH FROM THE BUTT BACK 200mm & PULL CABLE BACK UNTIL BUTT ENDS UP IN POSITION SHOWN.

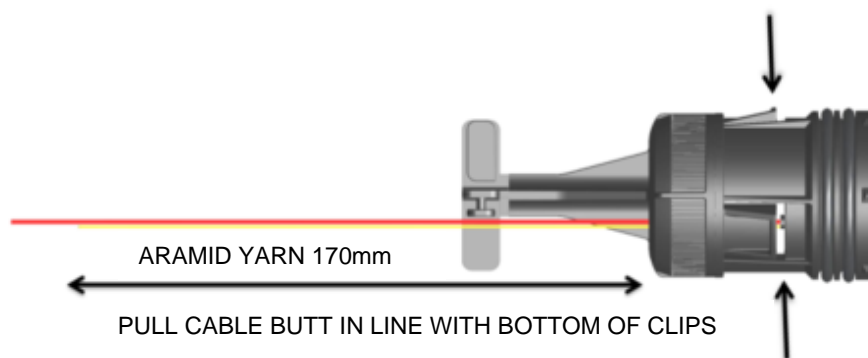

**MECH SEAL – 8-WAY 2.4mm &
3.0mm CABLE INSTALLATION GUIDE**

Step 10

SEPARATE THE ARAMID FROM THE FIBRES ENSURING IT IS GATHERED IN ONE DIRECTION AND NOW SQUEEZING THE FIBRES.

TEMPORARILY TUCK THE LOOSE FIBRE OUT OF THE WAY (BEHIND THE NEAREST ARAMID CHANNEL).

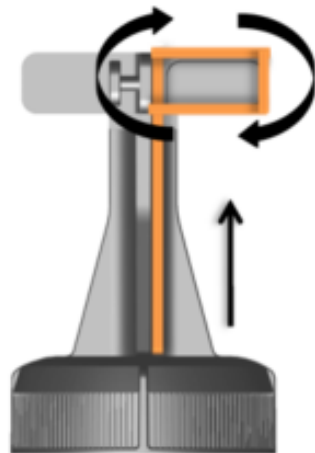

WHILST KEEPING TENSION ON THE CABLE, BEGIN TO WRAP THE ARAMID AROUND THE ARAMID CHANNEL STARTING FROM THE INSIDE TO OUTSIDE UNTIL A MINIMUM OF 1.5 TO 2 TURNS HAVE BEEN MADE.

NOTE: EACH ARAMID CHANNEL CAN HOLD 2 CABLES WORTH OF ARAMID.

**MECH SEAL – 8-WAY 2.4mm &
3.0mm CABLE INSTALLATION GUIDE**

Step 11

WHILST KEEPING TENSION ON THE ARAMID, SLIDE THE ARAMID RETENTION CLIP (13) INTO PLACE. IT SHOULD FEEL FIRM TO SLIDE ON. IF IT DOESN'T REMOVE THE CLIP AND MAKE ANOTHER TURN OF ARAMID AROUND THE ARAMID CHANNEL.

TRIM THE REMAINING ARAMID TAIL LEAVING 10mm MINIMUM.

REPEAT STEP 8 TO 11 AS MANY TIMES AS NECESSARY TO ADD ALL ADDITIONAL 2.4mm OR 3.0mm CABLES REQUIRED.

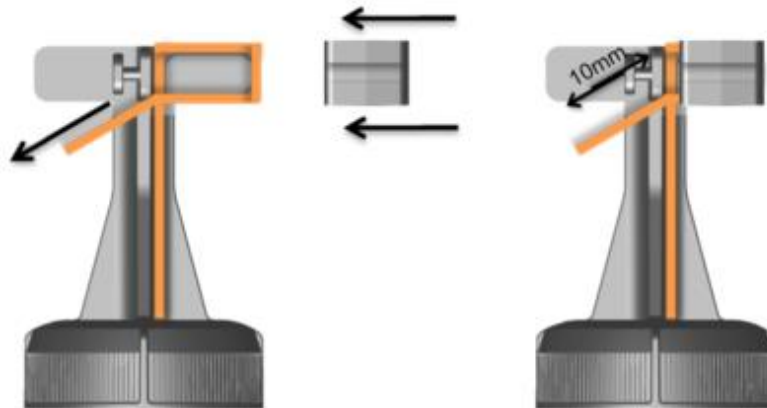

**MECH SEAL – 8-WAY 2.4mm &
3.0mm CABLE INSTALLATION GUIDE**

Step 12

FINALLY TIGHTEN THE MEDIUM NUT (2) DOWN TO THE BASE OF THE THREAD.

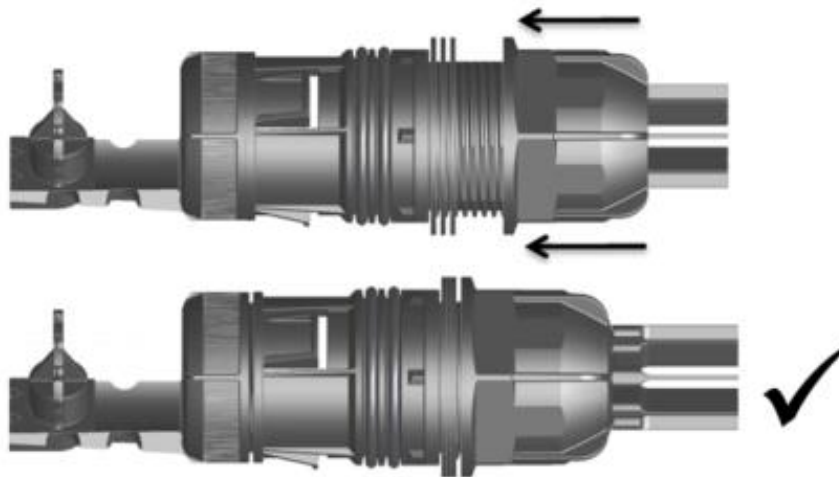

**MECH SEAL – 8-WAY 2.4mm &
3.0mm CABLE INSTALLATION GUIDE**

Step 13

PUSH GLAND (1) INTO CMJ BASE. ONCE RESISTANCE ON O-RING IS FELT, CONTINUE PUSHING WITH A TWISTING ACTION UNTIL AN AUDIBLE CLICK IS HEARD. VISUALLY CHECK FROM INSIDE THE BASE ALL 3 CLIPS ARE SECURED INTO BASE.

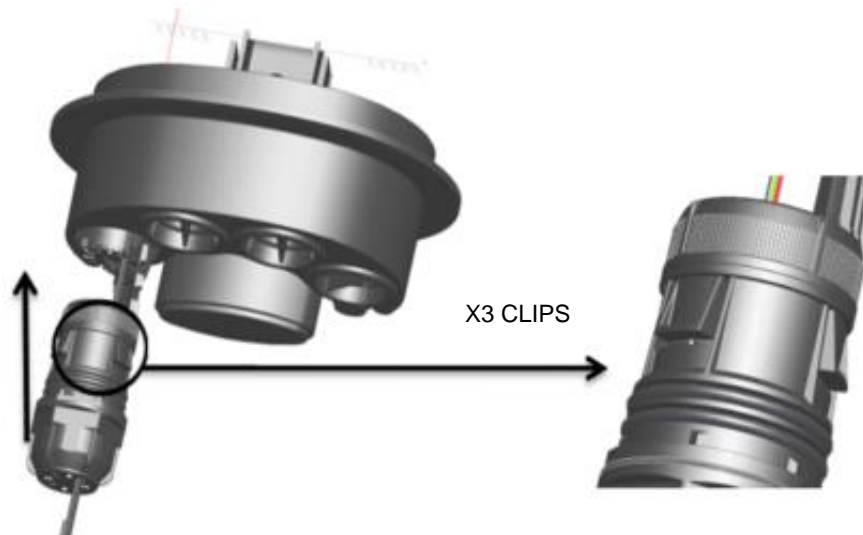

**MECH SEAL – 8-WAY 2.4mm &
3.0mm CABLE INSTALLATION GUIDE**

Step 14

INSERT THE FLAT DROP CABLE INTO THE MANIFOLD RESTRAINT AND ENSURE THE SHEATH ALIGNS AT THE INDICATED POSITION, AS SHOWN. ROUTE ELEMENTS AND FIBRES AS PER THE CLOSURE INSTALLATION INSTRUCTIONS.

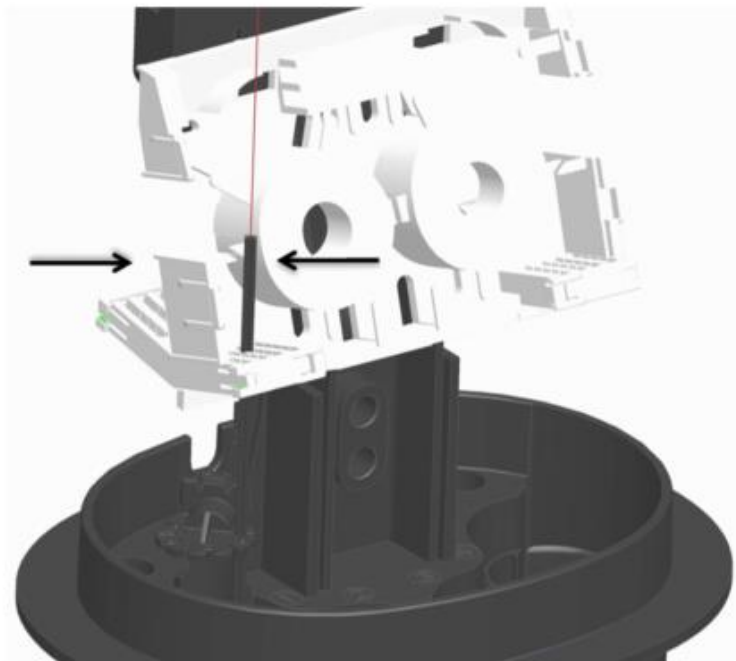

**MECH SEAL – 8-WAY 2.4mm &
3.0mm CABLE INSTALLATION GUIDE**

Step 15

ADDITIONAL CABLE INSTALLTION

TO INSTALL ADDITIONAL CABLES, LOOSEN THE MEDIUM NUT (2) AND REMOVE NUMBER OF BLANKS (10) REQUIRED TO NEW INSTALL NEW BEND LIMITING TUBE/2.4mm OR 3.0mm CABLES.



**MECH SEAL – 8-WAY 2.4mm &
3.0mm CABLE INSTALLATION GUIDE**

Step 16

ADDITIONAL CABLE INSTALLTION

FOR BEND LIMITING TUBE: FOLLOW CABLE PREPERATION STEPS 5 TO 7 & FINISH WITH STEP 12.

FOR 2.4mm OR 3.0mm DIAMETER CABLE: FOLLOW CABLE PREPERATION STEPS 8 TO 12.