

## MECH SEAL – 4-7mm SINGLE WAY GLAND INSTALLATION GUIDE

### KIT CONTENTS

ITEM No.:	DESCRIPTION	QTY
1	MEDIUM BODY SEALING GLAND	x1
2	MEDIUM NUT	x1
3	O-RING BS124 NITRILE	x2
4	STRENGTH MEMBER RETENTION BRACKET	x1
5	STRENGTH MEMBER RETENTION BOSS	x1
6	GRUB SCREW	x1
7	M4 x 12mm CSK POZI PAN SCREW	x1
8	4-7mm SINGLE WAY CABLE SEAL	x1
9	ANTI-TORSION CLAMP – SMALL	x1
10	JUBILEE CLIP 8-16mm – SMALL	x1
11	SPACERS	x2
12	GREASE SACHET	x1
13	FOAM TAPE 0.05m	x1



## **MECH SEAL – 4-7mm SINGLE WAY GLAND INSTALLATION GUIDE**

### **Step 1**

REMOVE PORT BLANK FROM BASE BY FULLY SQUEEZING TOGETHER THE TABS FROM INSIDE THE BASE.

**NOTE: YOU MAY NEED TO ROTATE THE BLANK IN THE PORT TO SQUEEZE THE TABS.**

USING YOUR OTHER HAND OR PLIERS, HOLD THE CENTRAL RIB AND FIRMLY PULL UNTIL THE PORT BLANK IS RELEASED.



**MECH SEAL – 4-7mm SINGLE WAY GLAND  
INSTALLATION GUIDE**

**Step 2**

IDENTIFY THE CABLE DIAMETER AND USING THE TABLE BELOW  
SELECT THE CORRECT NUMBER OF SPACERS REQUIRED.

<b>CABLE <math>\varnothing</math></b>	<b>SEAL SIZE (8)</b>	<b>CABLE RANGE</b>	<b>SPACERS (11)</b>
4mm – 6.9mm	4-7mm SEAL XJTSG01774	4-5mm	0
		5-6mm	1
		6-6.9mm	2

**MECH SEAL – 4-7mm SINGLE WAY GLAND  
INSTALLATION GUIDE**

**Step 3**

REMOVE THE MEDIUM NUT (2) FROM THE GLAND ASSEMBLY AND INSERT THE ANTI-TORSION CLAMP (9) AS SHOWN BELOW.

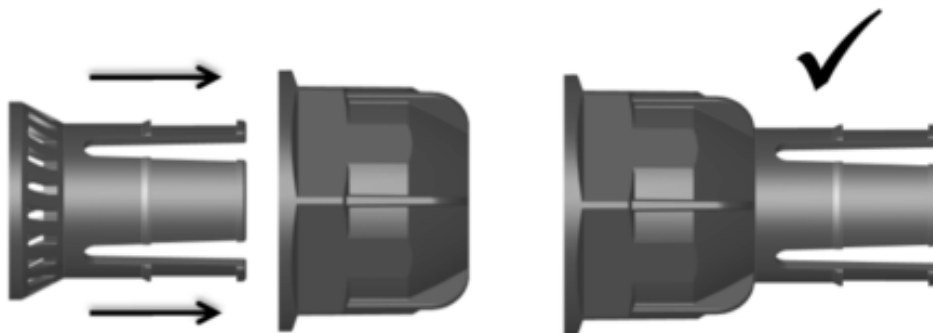

**MECH SEAL – 4-7mm SINGLE WAY GLAND  
INSTALLATION GUIDE**

**Step 4**

SLIDE THE JUBILEE CLIP (10) OVER THE CABLE END FIRST. THEN SLIDE THE MEDIUM NUT (2) AND ANTI-TORSION CLAMP (9) OVER THE CABLE END (FITTED TOGETHER).

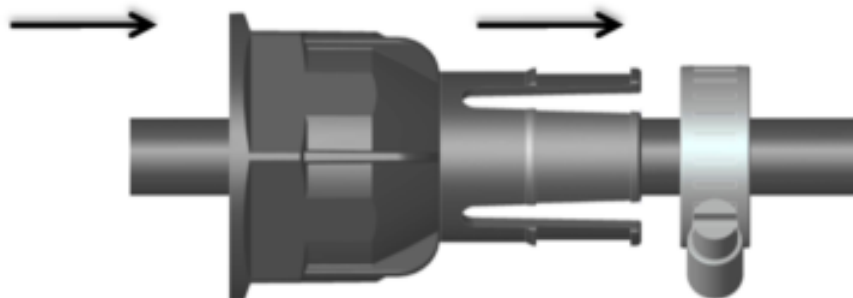

**MECH SEAL – 4-7mm SINGLE WAY GLAND  
INSTALLATION GUIDE**

**Step 5**

INSERT THE SEAL (8) INTO THE GLAND ASSEMBLY (1) AS SHOWN.



**MECH SEAL – 4-7mm SINGLE WAY GLAND  
INSTALLATION GUIDE**

**Step 6**

FIT THE REQUIRED NUMBER OF SPACERS (11) OVER THE THREAD OF THE GLAND BODY ASSEMBLY (1).



**MECH SEAL – 4-7mm SINGLE WAY GLAND  
INSTALLATION GUIDE**

**Step 7**

SLIDE THE GLAND ASSEMBLY (1) ONTO THE CABLE AND PUSH THROUGH APPROXIMATELY 2.2m OF CABLE. LOOSELY TIGHTEN THE MEDIUM NUT (2) BACK ONTO THE GLAND BODY AND LOOSELY TIGHTEN JUBILEE CLIP (10) ONTO THE ANTI-TORSION CLAMP (9).

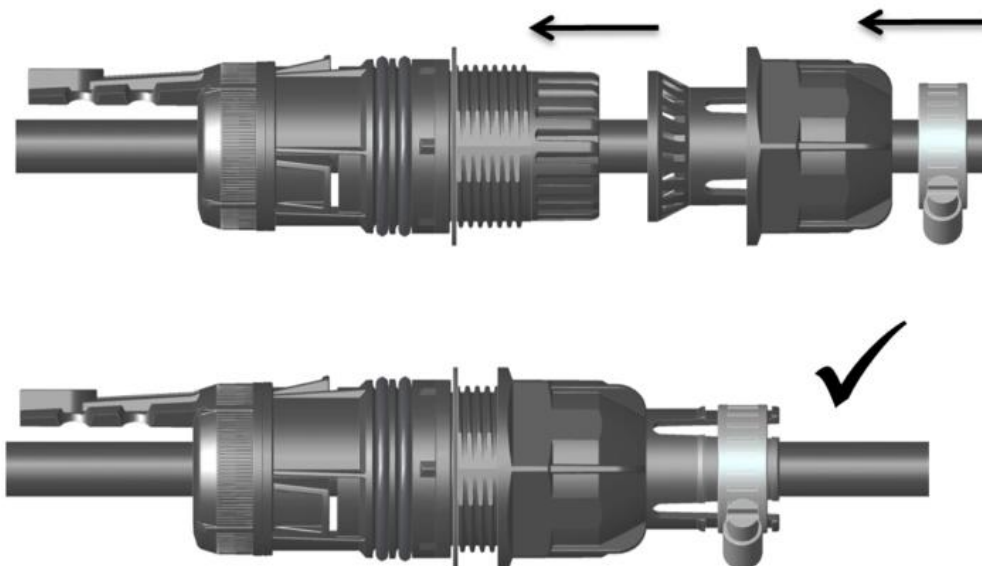



**MECH SEAL – 4-7mm SINGLE WAY GLAND  
INSTALLATION GUIDE**

**Step 8**

STRIP CABLE BACK 2m (CMJ, MMJ) or 3m (LMJ) EXPOSING THE ELEMENTS, GRP AND ARAMID YARN IF APPLICABLE. MEASURE FROM THE CABLE BUTT 70mm AND WRAP 1 TURN OF FOAM TAPE AROUND THE CABLE IN THE POSITION SHOWN.

MEASURE FROM THE CABLE BUTT AND CUT THE GPR TO 55mm AND CUT THE ARAMID YARN TO 170mm.

APPLY GREASE (12) ALONG CABLE SHEATH FROM THE BUTT BACK 200mm & PULL CABLE BACK UNTIL BUTT ENDS UP IN POSITION SHOWN.

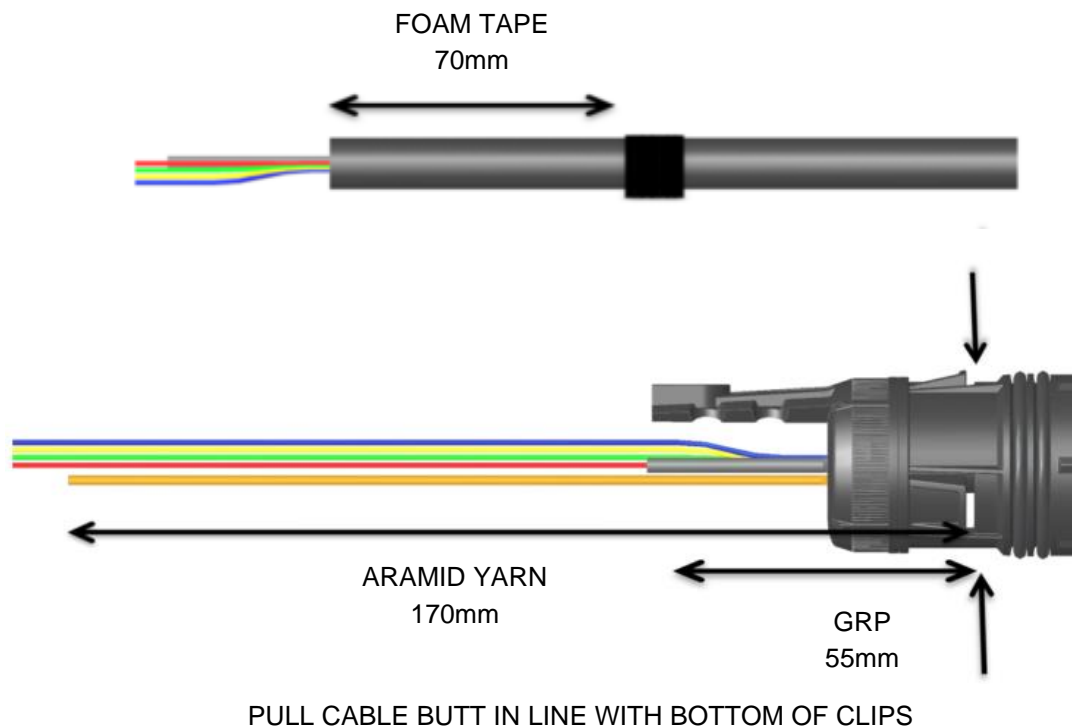

## MECH SEAL – 4-7mm SINGLE WAY GLAND INSTALLATION GUIDE

### Step 9

SLIDE RETENTION BOSS (5) OVER GRP AND LINE UP THE SCREW HOLE. SECURE RETENTION BOSS (5) TO THE RETENTION BRACKET (4) USING SCREW (7). ENSURE THE GROOVES LINE UP AT THE TOP. IF THE CABLE HAS ARAMID YARN SEE NOTE 10.

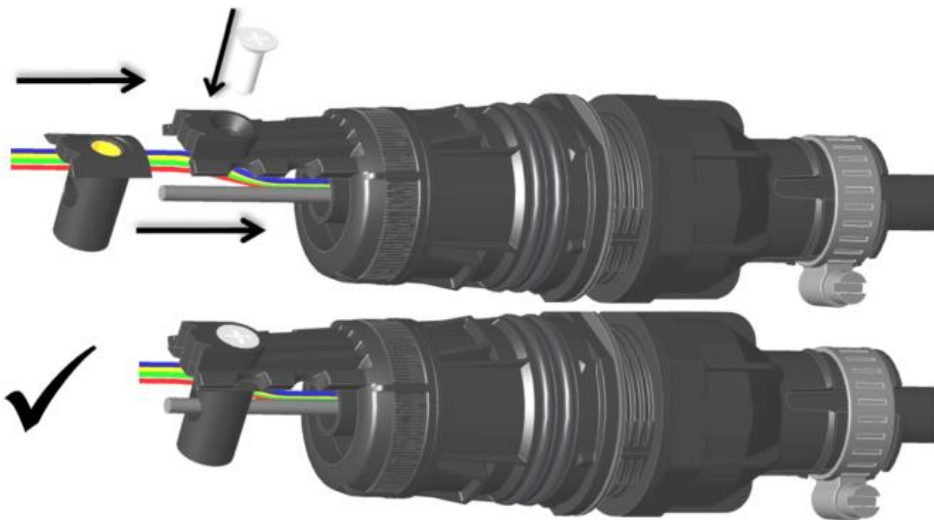

## MECH SEAL – 4-7mm SINGLE WAY GLAND INSTALLATION GUIDE

### Step 10

IF THE CABLE HAS ARAMID, LOOSELY FASTEN THE RETENTION BOSS (5) USING THE SCREW (7) AND SEPARATE THE ARAMID FROM THE ELEMENTS. WRAP THE ARAMID YARN AROUND THE SCREW x2 TURNS AND FINISH THE SECOND TURN WITH THE ARAMID FACING OUT TO THE SIDE AS SHOWN BELOW AND TIGHTEN THE SCREW (7) TO THE RETENTION BOSS (5) USING A SCREWDRIVER. TRIM EXCESS ARAMID.

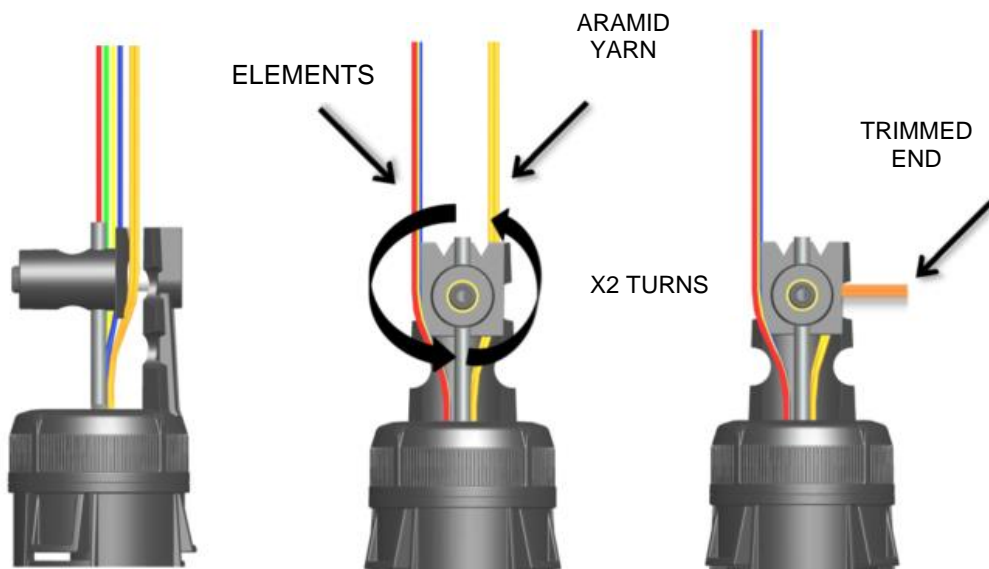

**MECH SEAL – 4-7mm SINGLE WAY GLAND  
INSTALLATION GUIDE**

**Step 11**

TIGHTEN THE GRUB SCREW (6) ONTO THE GRP USING 2MM ALLEN KEY. DO NOT OVER TIGHTEN.

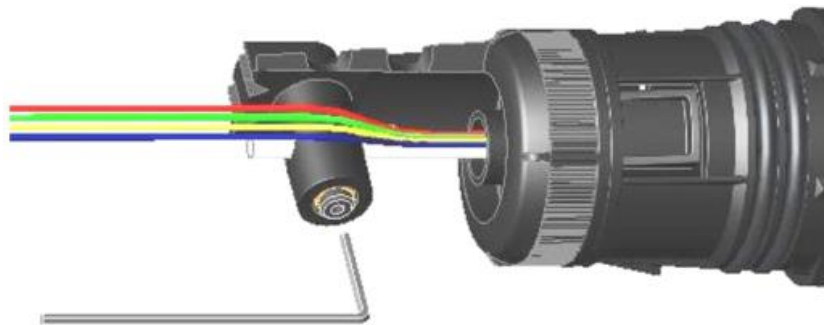

**MECH SEAL – 4-7mm SINGLE WAY GLAND  
INSTALLATION GUIDE**

**Step 12**

ENSURE THE SINGLE SEAL (8) IS FULLY INSERTED INTO GLAND BODY (1). LOCATE THE ANTI-TORSION CLAMP (9) NODULES AND PUSH THE CLAMP ONTO THE SEAL SO THE ANTI-TORSION CLAMP CANNOT ROTATE.

**NOTE: DO NOT FORCEFULLY ROTATE THE CLAMP.  
IF THE ANTI-TORSION CLAMP ROTATES, IT HAS NOT BEEN  
LOCATED CORRECTLY.**

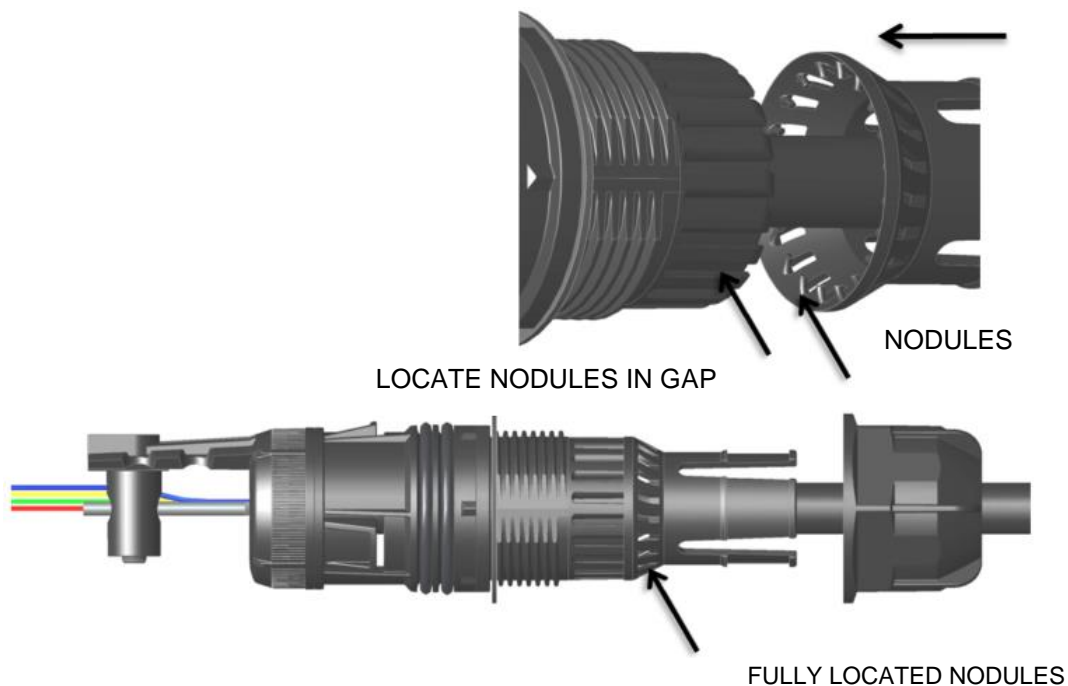

## MECH SEAL – 4-7mm SINGLE WAY GLAND INSTALLATION GUIDE

### Step 13

SLIDE THE MEDIUM NUT (2) OVER THE ANTI-TORSION CLAMP AND SCREW THE NUT DOWN UNTIL ALL THE SURFACES MATE. ENSURE THE ANTI-TORSION CLAMP STAYS LOCATED BY PUSHING DOWN ON THE END WHILST IN POSITION. USING JUBLIEE CLIP (10), SLIDE IT OVER THE END OF CLAMP AND TIGHTEN USING SCREWDRIVER.

**NOTE: DO NOT OVER TIGHTEN ON CABLE.**

APPLY 2 TURNS OF ELECTRICAL TAPE OVER THE JUBILEE CLIP.

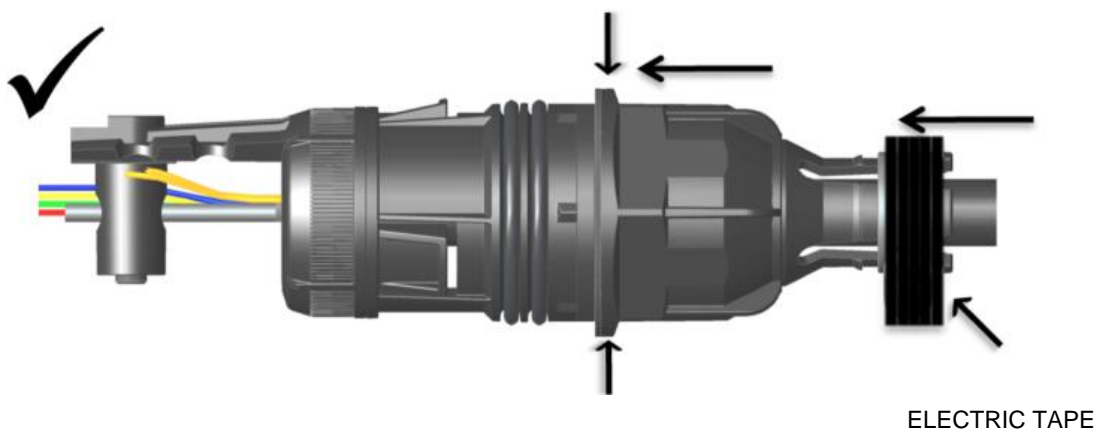

**MECH SEAL – 4-7mm SINGLE WAY GLAND  
INSTALLATION GUIDE**

**Step 14**

PUSH GLAND (1) INTO CMJ/MMJ/LMJ BASE. ONCE RESISTANCE ON O-RING IS FELT, CONTINUE PUSHING WITH A TWISTING ACTION UNTIL AN AUDIBLE CLICK IS HEARD. VISUALLY CHECK FROM INSIDE THE BASE ALL 3 CLIPS ARE SECURED INTO BASE.

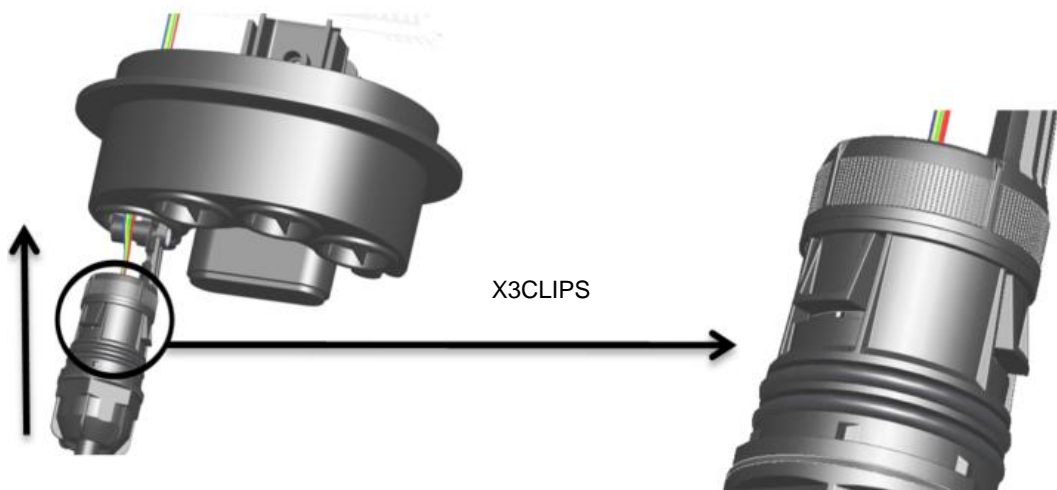

## MECH SEAL – 4-7mm SINGLE WAY GLAND INSTALLATION GUIDE

### Step 15

INSERT THE CABLE TUBE INTO THE MANIFOLD RESTRAINT AND STRIP THE TUBE AT THE INDICATED POSITION, AS SHOWN. ROUTE ELEMENTS AND FIBRES AS PER THE CLOSURE INSTALLATION INSTRUCTIONS.

