

Prysmian
Group
INSTALLATION INSTRUCTION

MECH SEAL OVAL PORT KIT CMJ / MMJ











Description

The CMJ / MMJ Oval Port Mechanical Seal kit is used to prepare and install a mid-span loop of cable into the oval port of the closure.

Tools Required

Tools:
Large Screwdriver, File, Torque Wrench.

Component Parts (pictures not to scale)

<p>1 Rubber Seal Qty 1</p> 	<p>2 External Plate Qty 2</p> 	<p>3 Internal Plate Qty 2</p> 	<p>4 Cable Anchor Plate Qty 1</p> 
<p>5 Washer M6 Qty 2</p> 	<p>6 Screw M6x20 Qty 2</p> 	<p>7 Grease Sachet Qty 1</p> 	
<p>9 Screw Set M4 x 10 Qty 2</p> 	<p>10 Allen Key 2mm Qty 1</p> 	<p>11 Allen Key 5mm Qty 1</p> 	

JOINT AND CABLE PREPARATION

Step 1



- Knock out the oval port end plate of the Joint from the inside using a large screwdriver and remove any burrs using a file.

JOINT AND CABLE PREPARATION

Step 2

Mark centre point of mid span window

- Remove the cables from the footway box and apply a reference mark to the cable where the centre of the window cut will be made.

JOINT AND CABLE PREPARATION

Step 3

Joint Type	Cable Type	Loop Length
UMJ	8 tubes MAX. Ø1.35mm	2500mm
	8 tubes MAX. Ø1.5mm	1800mm
CMJ	Loose Tube 6 tubes MAX. Ø1.65mm	2400 mm
CMJ	Flex tube	2500 mm
MMJ	Loose Tube	2700 mm
MMJ	Flex tube	2700 mm

- Identify the length of the mid span window required by identifying the joint and cable type from the table above.

JOINT AND CABLE PREPARATION

Step 4

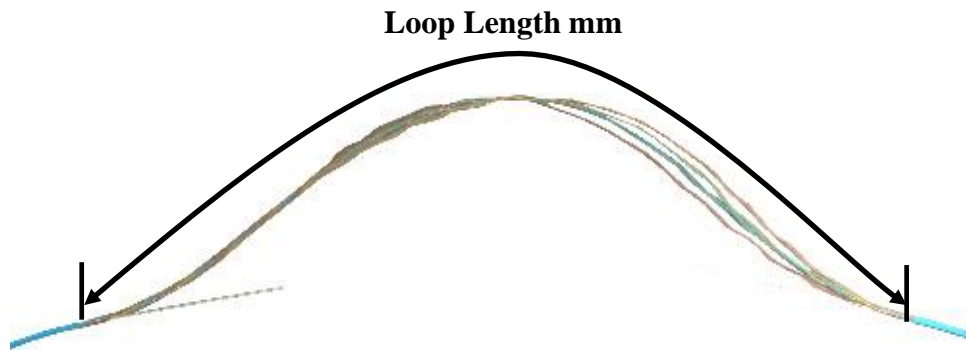

Remove a window of cable sheath

- Apply two butt marks back either side of the mid span mark half the distance of the overall loop length. Before removing the sheath double check the two butt marks are the correct distance apart referring to the table in step 4.
- Remove the cable sheath between the two butt marks using approved practices.

JOINT AND CABLE PREPARATION

Step 5

Go to Step 6 if your cable has GRP

Go to Step 7 if your cable has Aramid Yarn

- Identify if your cable is using GRP or Aramid Yarn.
- Go to the relevant step for the preparation process.

JOINT AND CABLE PREPARATION

Step 6

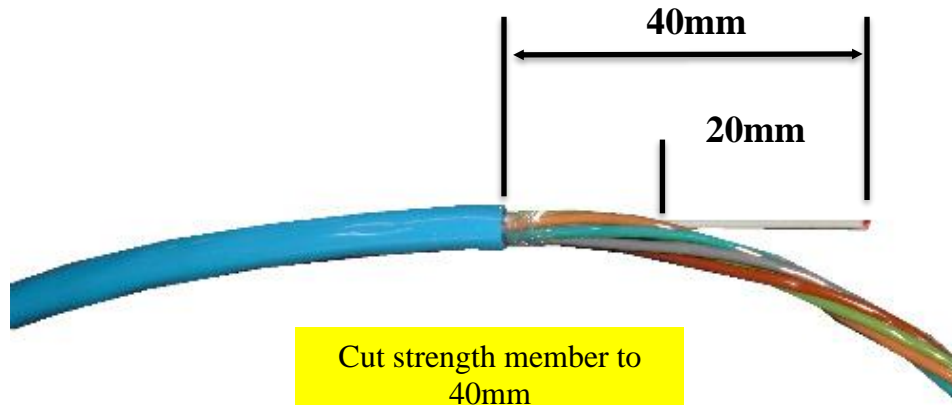

Cut strength member to
40mm

Remove 20mm of sheath
from strength member

- Remove all tapes and binders.
- Access the central strength member and cut it in the centre.
- Cut each end back to 40mm from the cable butt as shown. Remove 20mm of sheath from CSM if the CSM diameter is greater than 5mm.

GO TO STEP 8

JOINT AND CABLE PREPARATION

Step 7

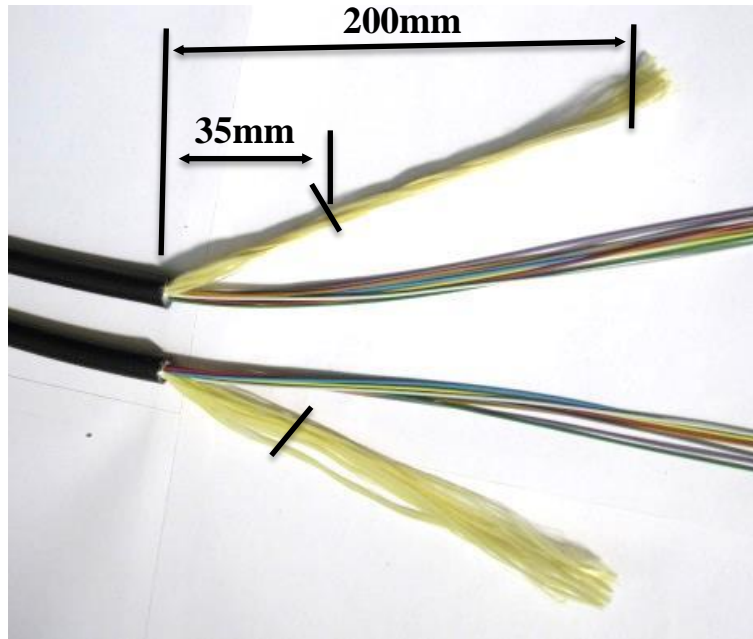

- Remove all tapes and binders.
- Access the aramid yarns and cut it in the centre.
- Cut each end back to 200mm from the cable butt as shown.
- Mark the aramid yarns with permanent marker 35mm from the cable butt.

GO TO STEP 8

JOINT AND CABLE PREPARATION

Step 8

WARNING!

**DOUBLE CHECK THE CABLE DIAMETER BEFORE
INSTALLING THE MECHANICAL SEAL.**

- It is important to check again at this point the nominal CABLE diameter.
- Use the lower tolerance to measure the appropriate oval seal size to install.

OVAL MECH SEAL INSTALLATION

Step 9

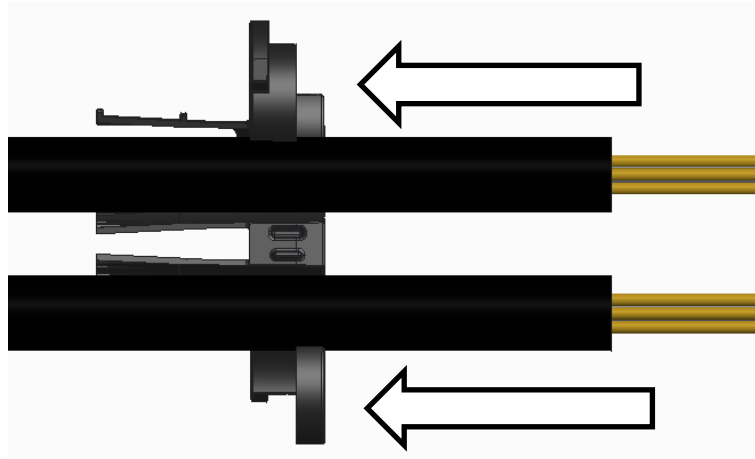

- Using the first external plate lay over the cable into the cable slots.
- Ensure correct orientation, as shown.

OVAL MECH SEAL INSTALLATION

Step 10

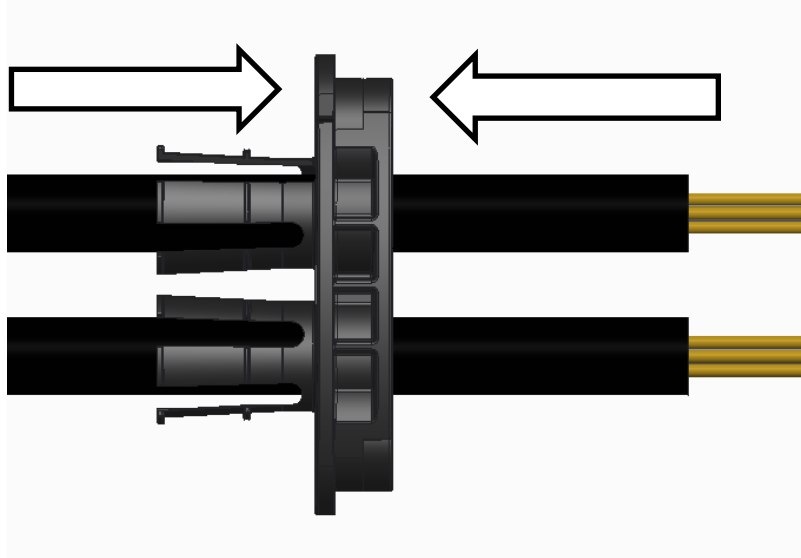

- Place the second external plate over the cable. *See Step 11 & 12 for detailed assembly.*
- Ensure the lugs are interlocked correctly as shown.

OVAL MECH SEAL INSTALLATION

Step 11

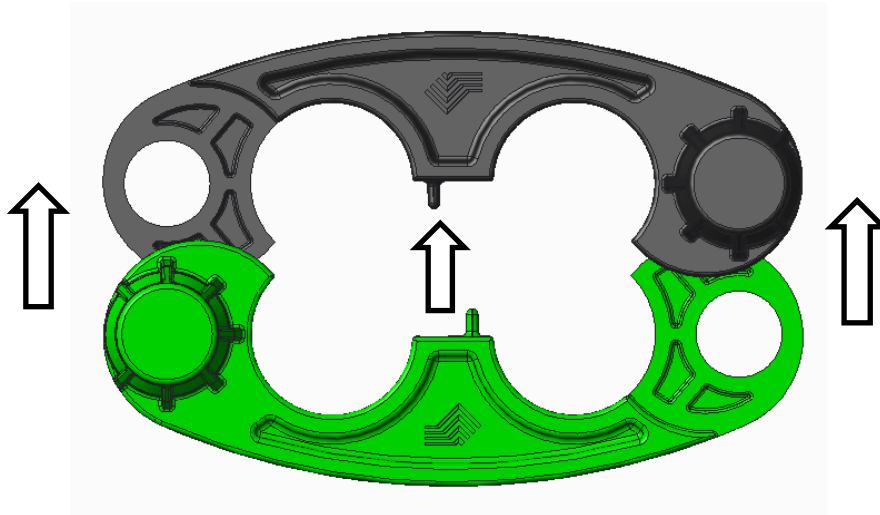

- Using the internal or external plates slide the plates together.
- The central pins will locate the correct positioning.
- The screw holes will align.

NOTE: Two colours used for clarification.

OVAL MECH SEAL INSTALLATION

Step 12



- Correct assembly position and alignment of internal or external plates.

NOTE: Two colours used for clarification.

OVAL MECH SEAL INSTALLATION

Step 13

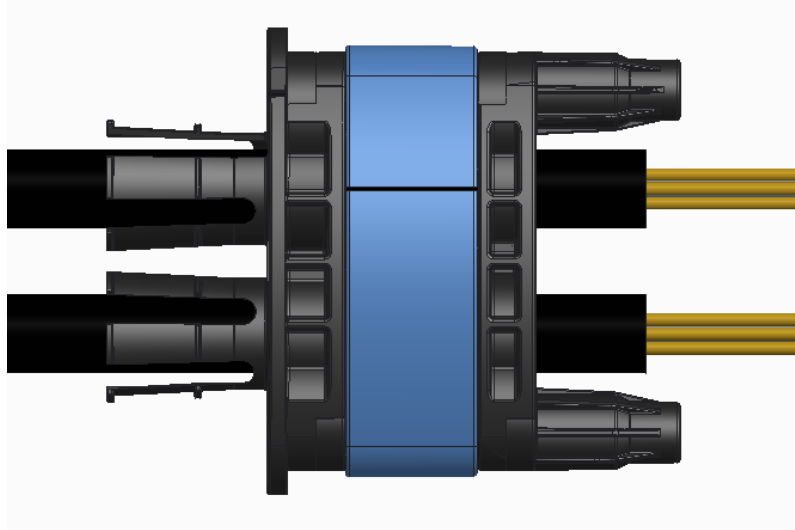

- Add the rubber seal and internal plates to the assembly on the cable.
- Ensure correct orientation of internal plate as shown.

OVAL MECH SEAL INSTALLATION

Step 14

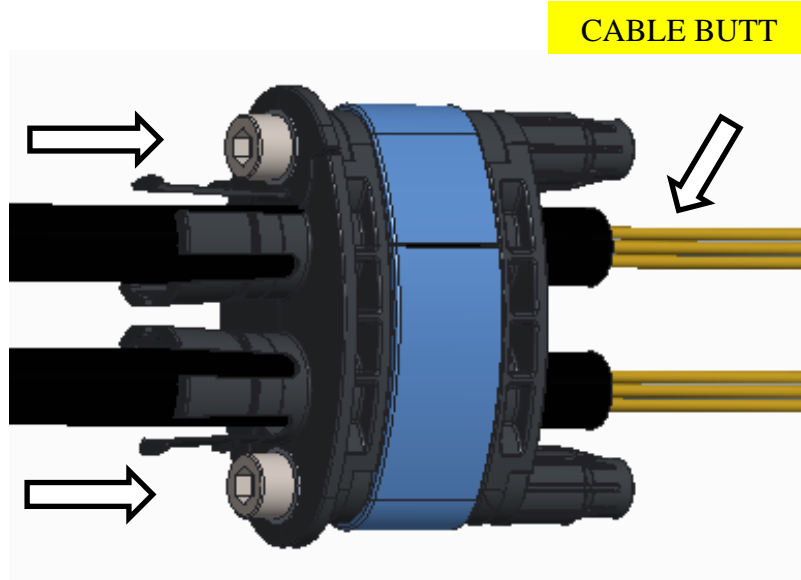

- Hold the assembly gently together.
- Insert washers and screws.
- Lightly screw the assembly together.
- Ensure the cable butt protrudes through the internal plates.

OVAL MECH SEAL INSTALLATION

Step 15

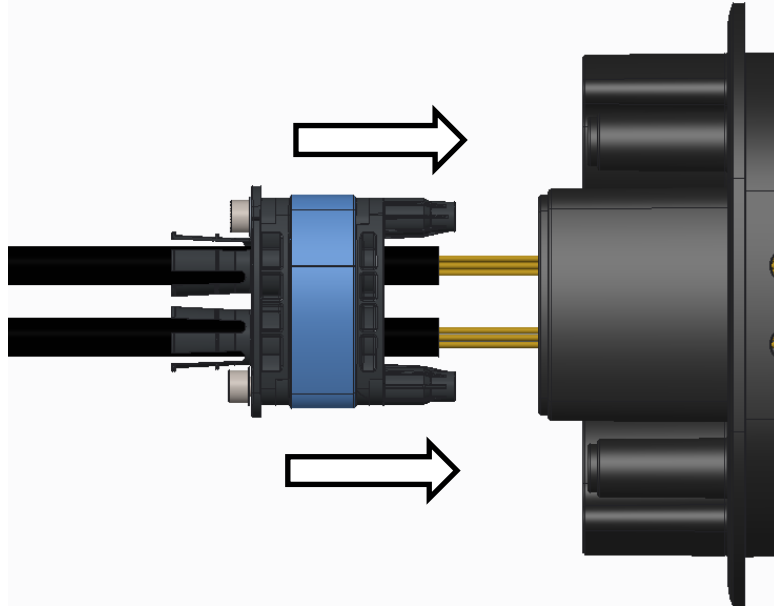

- Insert loop into the oval.
- Ensure aramids or strength members are pulled through carefully.
- Insert Mechanical Seal Oval Port assembly into the port fully.

OVAL MECH SEAL INSTALLATION

Step 16

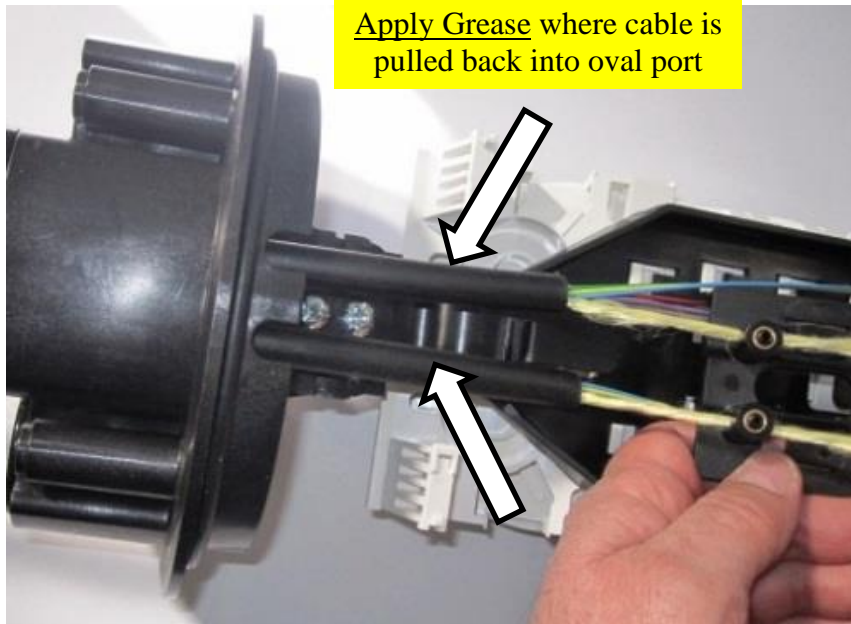

- Insert the GRP or ARAMID (or WIRES) into the slots of the Cable Anchor Plate.
- Ensure you twist/braid the aramid together before threading through the slot.
- Apply grease to this area of the cable before pulling the cable back into position.

NOTE: Ensure to wear protective gloves when installing wires.

OVAL MECH SEAL INSTALLATION

Step 17

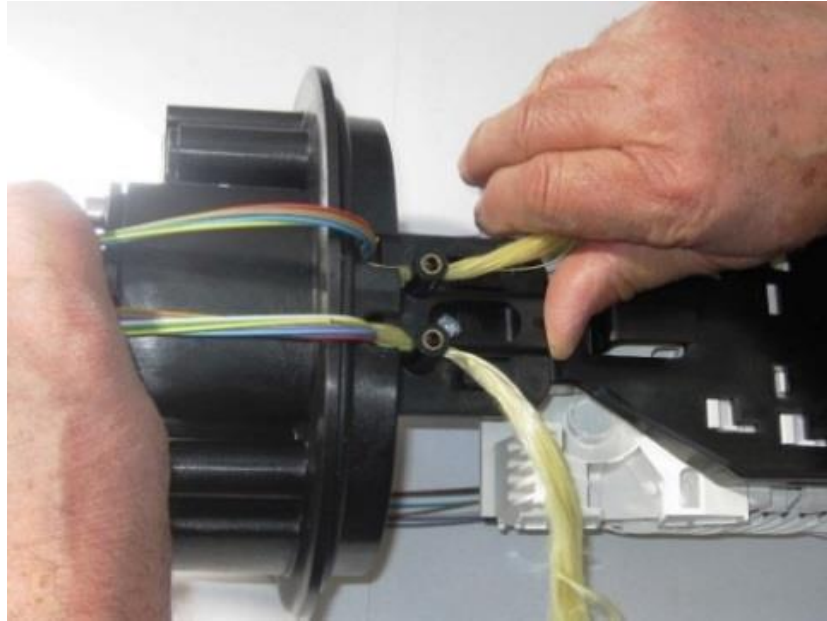

- Carefully move the elements out of the way and secure with one hand.
- Push the Cable Anchor Plate in position until you hear an audible click.

OVAL MECH SEAL INSTALLATION

Step 18

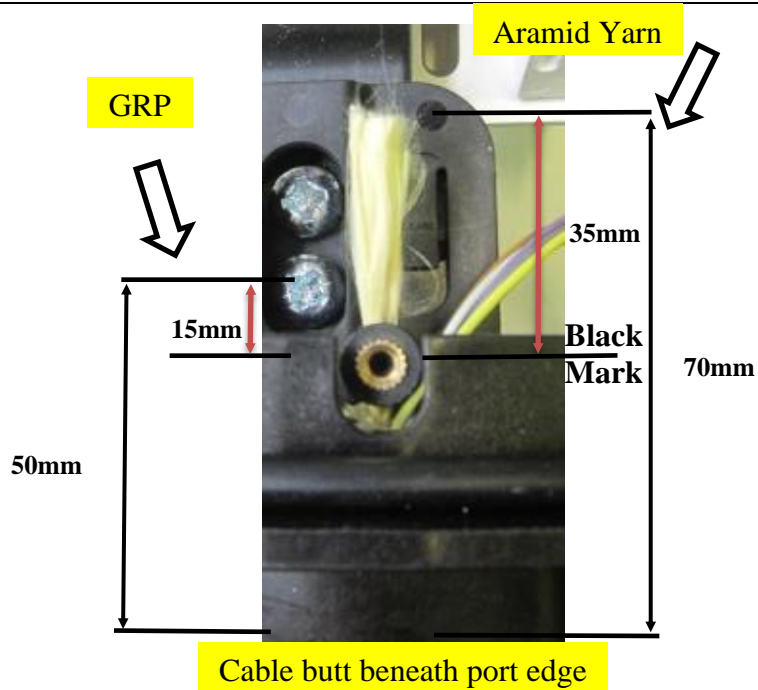

- Use the dimensions to ensure you have placed the cable butt in the correct position before securing the GRP or ARAMID.
- Using a pen mark on the aramid or GRP the pull back dimensions above.

OVAL MECH SEAL INSTALLATION

Step 19

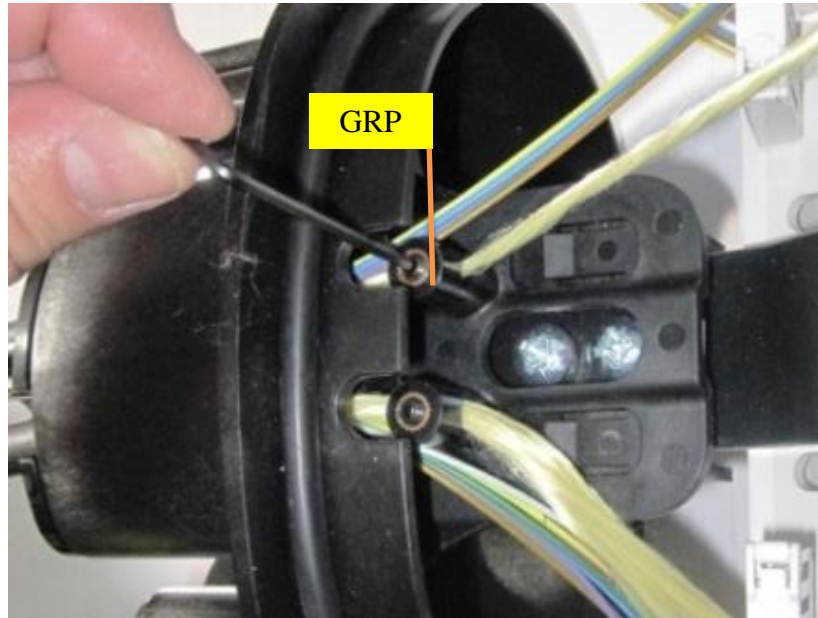

- Pull the cables back until the black mark on aramid or GRP is located under the grub screw.
- Use the 2mm Allen key to anchor the grub screw into the GRP/ARAMID.

**IF INSTALLING ARAMID GO TO STEP 20.
IF INSTALLING GRP GO TO STEP 21.**

OVAL MECH SEAL INSTALLATION

Step 20



- Trim the aramid to 35mm as per diagram in STEP 18.
- Ensure aramid is taught and cables are pulled back into position.

OVAL MECH SEAL INSTALLATION

Step 21

Oval Seal mm	Cable Diameter	Torque Setting Nm
5-7	5mm	3Nm
	7mm	2.5Nm
7-9	7mm	3Nm
	9mm	2.5Nm
9-11	9mm	2.5Nm
	11mm	2.5Nm
11-13	11mm	2.5Nm
	13mm	2.5Nm
13-15	13mm	2.5Nm
	15mm	2.5Nm

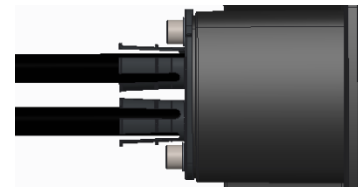

- Ensure mechanical seal is fully inserted.
- Using the table shown tighten screws to using a Torque Wrench.
- Ensure you tighten each screw evenly and in small increments, a few turns at a time, until Torque value is reached.

**IF INSTALLING CONDUIT GO TO STEP 22.
NO CONDUIT? GO TO STEP 23.**

OVAL MECH SEAL INSTALLATION

Step 22

IF USING CONDUIT, SLIDE TO THIS POINT

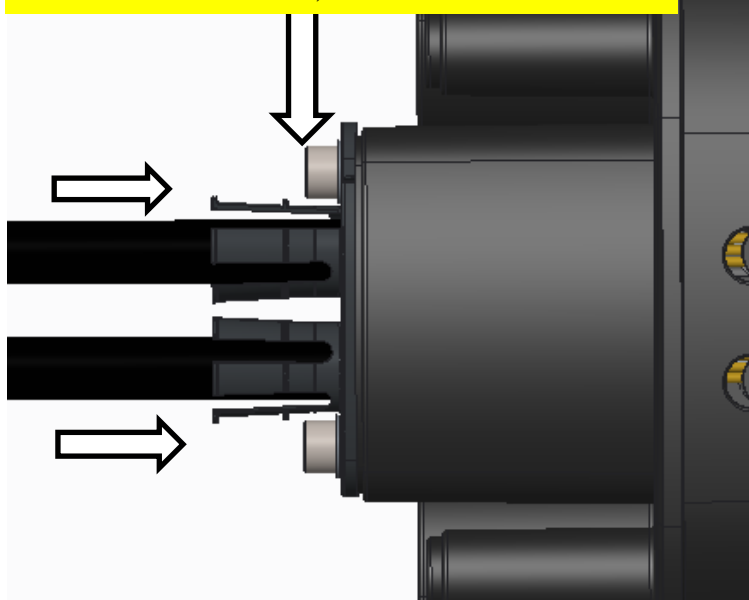

- If using conduit (e.g. COF205) slide it up to bottom of the port and secure using 2 cable ties.

NOTE: SKIP THIS STEP IF NOT INSTALLING CONDUIT

OVAL MECH SEAL INSTALLATION

Step 23

CMJ LOOP INSTALLATION

Go to step 24

MMJ LOOP INSTALLATION

Go to step 27

- For CMJ loop installation follow steps 24 to 26.
- For MMJ loop installation go to step 27 to 29.

CMJ LOOP INSTALLATION

Step 24

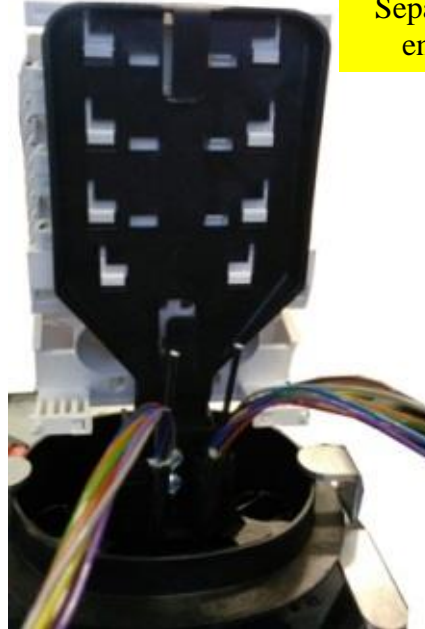

Separate the two
ends of loop

- First separate the two ends of the loop. Gently straighten the loop away from the CMJ ready to loop into the spine.

NOTE: Take care not to kink the cable elements when installing the loop. Do not rush and follow the instructions precisely.

CMJ LOOP INSTALLATION

Step 25

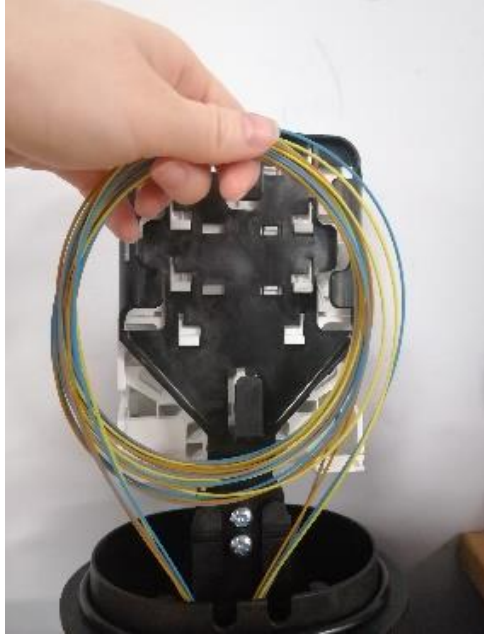

- Roughly make a loop the same diameter as the loop storage area.
- Cross the elements at the top and flip the loop over to gather the elements into a second loop.
- Repeat and alternate top and bottom until all the elements have been gathered into one circle.

CMJ LOOP INSTALLATION

Step 26

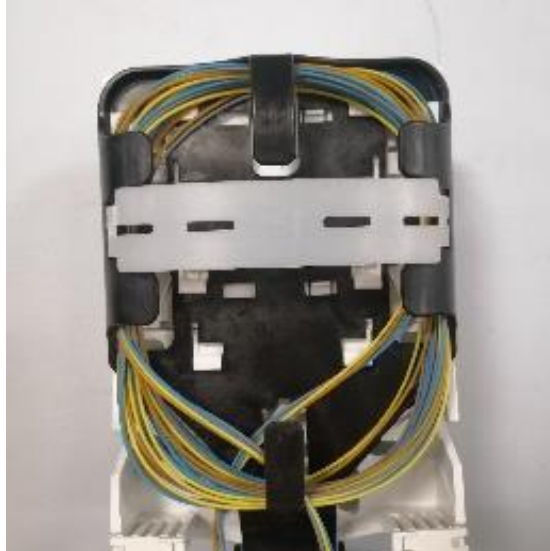

A single loop should be remaining after several coils have been installed.

- Roughly make a loop the same diameter as the loop storage area.
- Cross the elements at the top and flip the loop over to gather the elements into a second loop.
- Repeat and alternate top and bottom until all the elements have been gathered into one circle.

MMJ LOOP INSTALLATION

Step 27



Separate the two
ends of loop

- First separate the two ends of the loop. Gently straighten the loop away from the MMJ ready to loop into the spine.

NOTE: Take care not to kink the cable elements when installing the loop. Do not rush and follow the instructions precisely.

MMJ LOOP INSTALLATION

Step 28

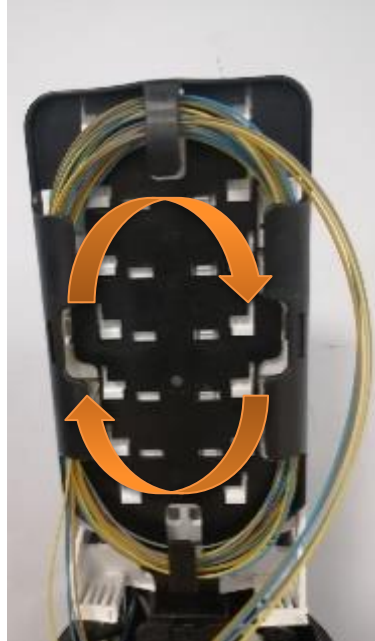

- Line up the left-hand side cable elements with the left side of the spine.
- Feed the tubes around in a clockwise direction beneath the tabs for one turn.
- Line up the right-hand side cable elements with the right side of the spine.
- Feed the tubes around in an anti-clockwise direction for one turn.

MMJ LOOP INSTALLATION

Step 29

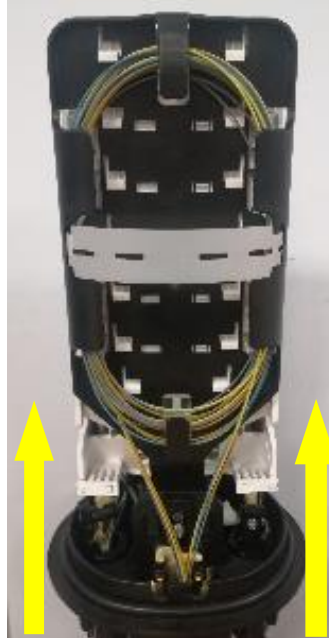

A single loop should be remaining after several coils have been installed.

- Repeat the process until one loop is left.
- Twist the remaining loop over and store beneath the tabs of the loop guide.
- Ensure the loop ends are vertical.
- Ensure to get most of the loop within the side walls of the spine and secure carefully using the plastic strap.