

## MECH SEAL – CCJ GLAND INSTALLATION GUIDE

### KIT CONTENTS

ITEM No.:	DESCRIPTION	QTY
1	MEDIUM BODY SEALING GLAND	x1
2	MEDIUM NUT	x1
3	O-RING BS124 NITRILE	x2
4	RESIN PORT ATTACHMENT	x1
5	RESIN PORT TOP PLATE	x1
6	GRUB SCREW	x1
7	11-16mm SINGLE WAY CABLE SEAL	x1
8	ANTI-TORSION CLAMP – LARGE	x1
9	JUBILEE CLIP 16-27mm – LARGE	x1
10	SPACERS	x3
11	GREASE SACHET	x1

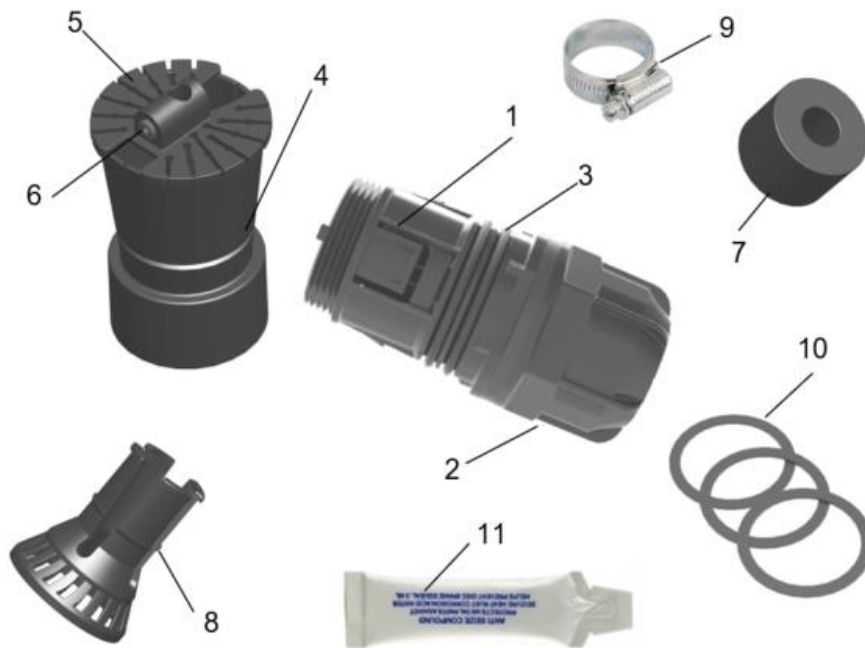

## MECH SEAL – CCJ GLAND INSTALLATION GUIDE

### Step 1

REMOVE PORT BLANK FROM BASE BY FULLY SQUEEZING TOGETHER THE TABS FROM INSIDE THE BASE.

**NOTE: YOU MAY NEED TO ROTATE THE BLANK IN THE PORT TO SQUEEZE THE TABS.**

USING YOUR OTHER HAND OR PLIERS, HOLD THE CENTRAL RIB AND FIRMLY PULL UNTIL THE PORT BLANK IS RELEASED.

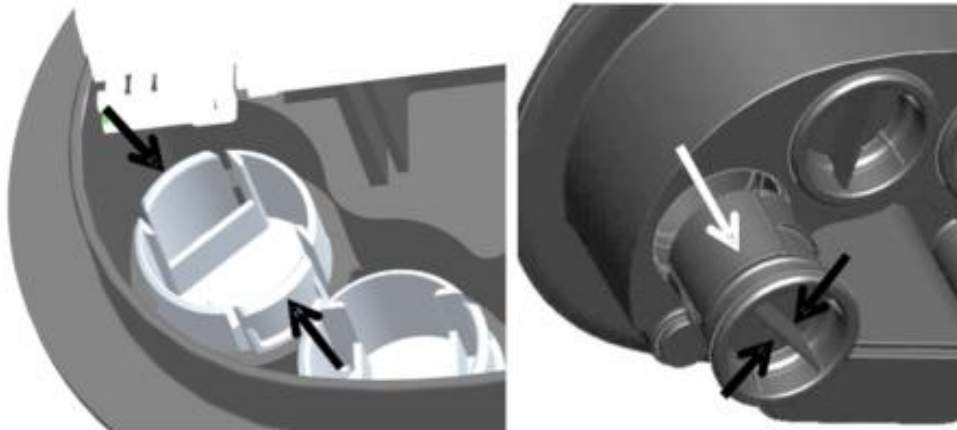

## MECH SEAL – CCJ GLAND INSTALLATION GUIDE

### Step 2

REMOVE THE MEDIUM NUT (2) FROM THE GLAND ASSEMBLY AND INSERT THE ANTI-TORSION CLAMP (8) AND JUBILEE CLIP (9) ONTO THE CABLE AS SHOWN BELOW.

SLIDE THE JUBILEE CLIP (9) OVER THE CABLE END FIRST. THEN SLIDE THE MEDIUM NUT (2) AND ANTI-TORSION CLAMP (8) OVER THE CABLE END.

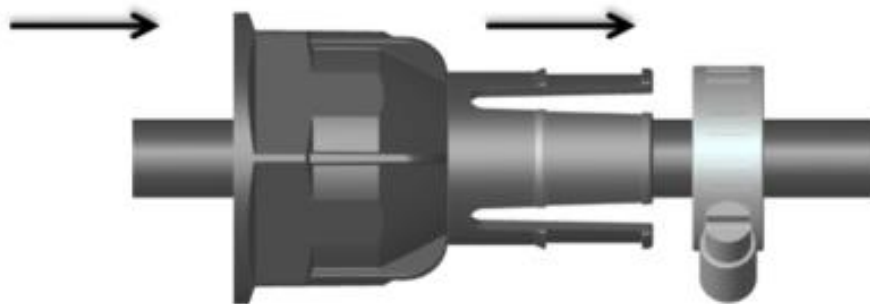

## MECH SEAL – CCJ GLAND INSTALLATION GUIDE

### Step 3

STRIP CABLE BACK 2m (SMALL & MEDIUM TM NODE) or 3m (LARGE & EXTRA-LARGE TM NODE) EXPOSING THE ELEMENTS, GRP AND ARAMID YARN IF APPLICABLE.

MEASURE FROM THE CABLE BUTT AND CUT THE GRP TO 125mm

APPLY GREASE (11) ALONG CABLE SHEATH FROM THE BUTT BACK 200mm.

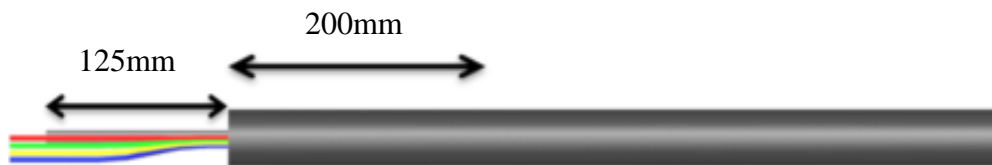

## MECH SEAL – CCJ GLAND INSTALLATION GUIDE

### Step 4

INSERT THE SEAL (7) ONTO THE CABLE LEAVING APPROX 5MM DISTANCE FROM THE END OF THE CABLE BUTT AS SHOWN. (MARK THE CABLE AT THE END OF THE SEAL TO USE AS A REFERENCE POINT AS ONCE THE SEAL IS PLACED ONTO THE CABLE IT IS IMPORTANT THAT IT DOES NOT MOVE/SLIDE ALONG THE CABLE).

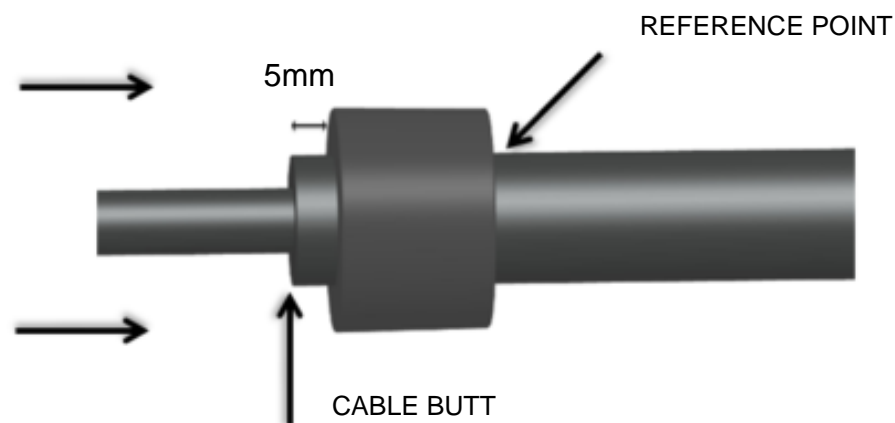

## MECH SEAL – CCJ GLAND INSTALLATION GUIDE

### Step 5

FIT THE 3 SPACERS (10) OVER THE THREAD OF THE GLAND BODY ASSEMBLY (1).

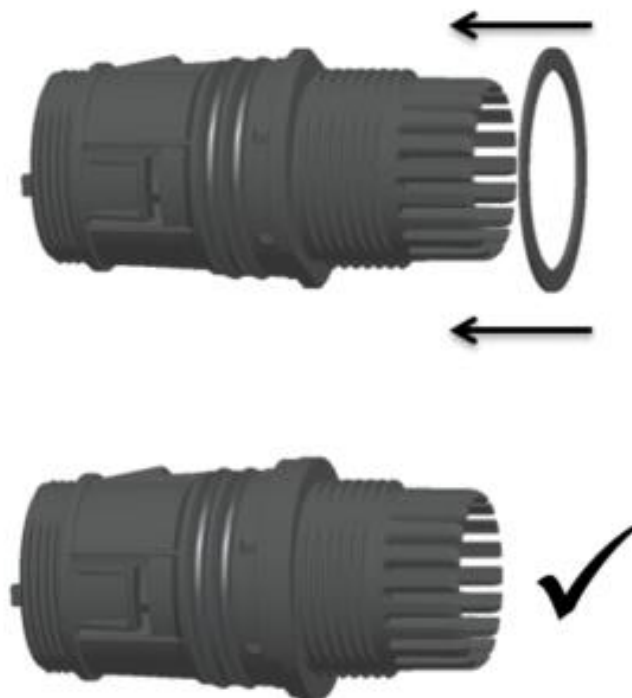

## MECH SEAL – CCJ GLAND INSTALLATION GUIDE

### Step 6

INSERT THE SEAL AND CABLE INTO THE GLAND ENSURING THAT THE SEAL POSITION REMAINS FIXED ON THE CABLE. (SEE STEP 4)

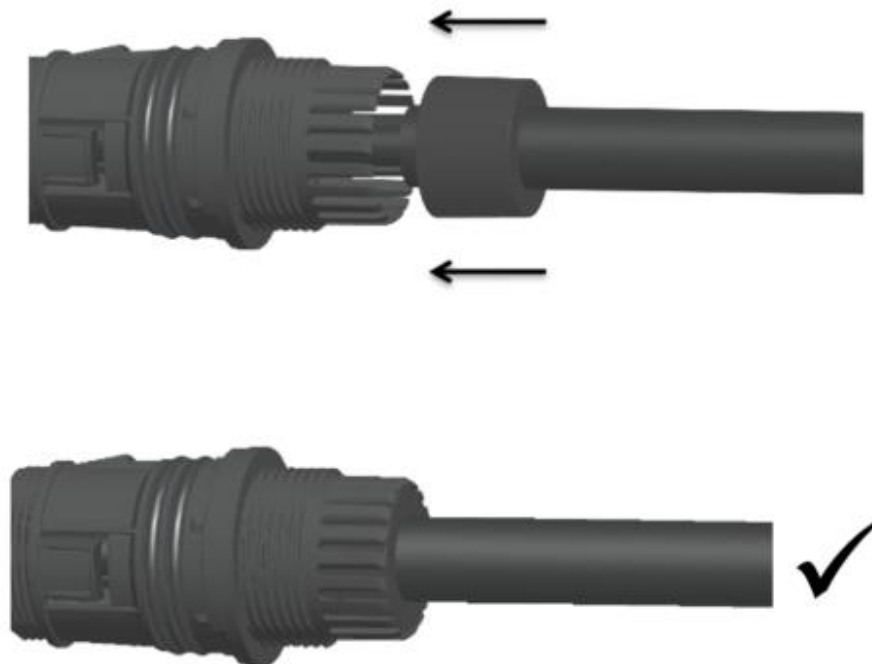

## MECH SEAL – CCJ GLAND INSTALLATION GUIDE

### Step 7

ENSURE THE SINGLE SEAL (7) IS FULLY INSERTED INTO GLAND BODY (1). LOCATE THE ANTI-TORSION CLAMP (8) NODULES AND PUSH THE CLAMP ONTO THE SEAL SO THE ANTI-TORSION CLAMP CANNOT ROTATE.

**NOTE: DO NOT FORCEFULLY ROTATE THE CLAMP. IF THE ANTI-TORSION CLAMP ROTATES, IT HAS NOT BEEN LOCATED CORRECTLY.**

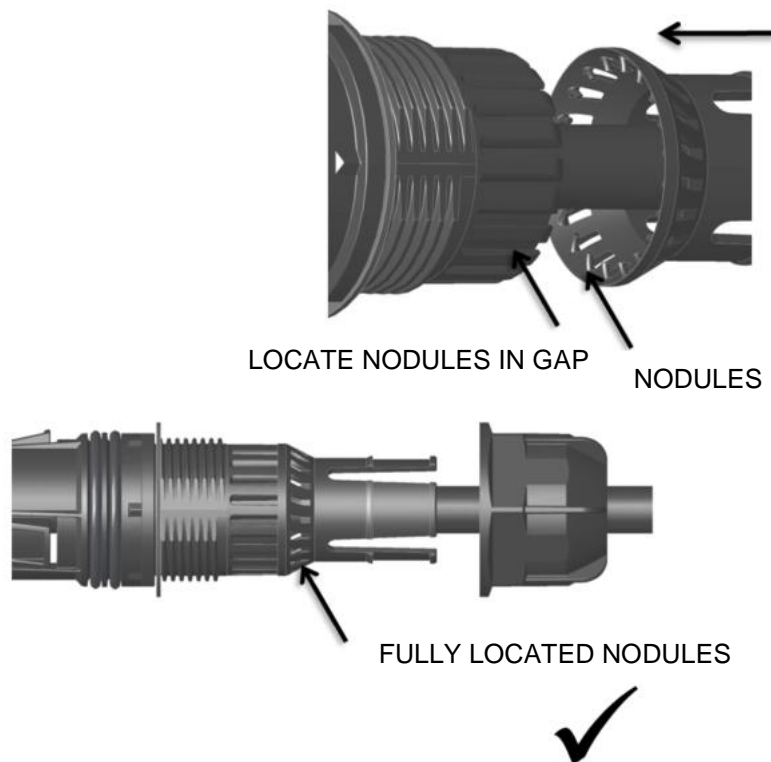



## MECH SEAL – CCJ GLAND INSTALLATION GUIDE

### Step 8

SLIDE THE MEDIUM NUT (2) OVER THE ANTI-TORSION CLAMP AND SCREW THE NUT DOWN UNTIL ALL THE SURFACES MATE. ENSURE THE ANTI-TORSION CLAMP STAYS LOCATED BY PUSHING DOWN ON THE END WHILST IN POSITION. USING JUBLIEE CLIP (9), SLIDE IT OVER THE END OF CLAMP AND TIGHTEN USING SCREWDRIVER.

**NOTE: DO NOT OVER TIGHTEN ON CABLE.**

APPLY 2 TURNS OF ELECTRICAL TAPE OVER THE JUBILEE CLIP.

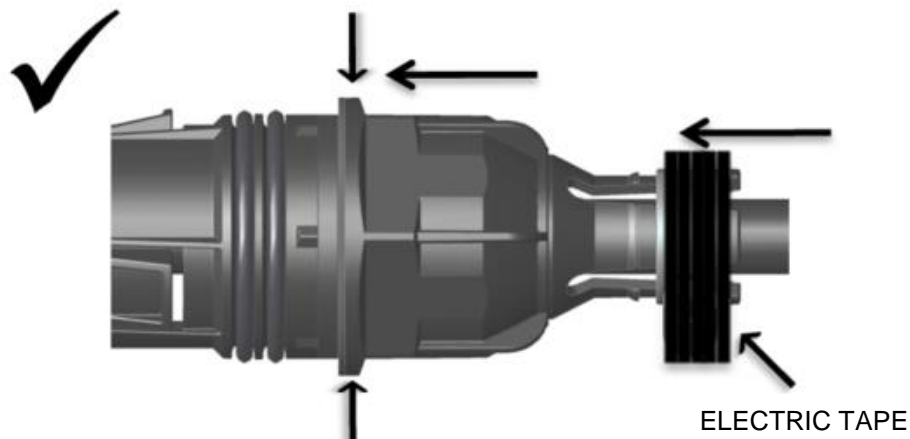

## MECH SEAL – CCJ GLAND INSTALLATION GUIDE

### Step 9

PUSH GLAND (1) INTO THE S/M/L/XL TM NODE BASE. ONCE RESISTANCE ON O-RING IS FELT, CONTINUE PUSHING WITH A TWISTING ACTION UNTIL AN AUDIBLE CLICK IS HEARD. VISUALLY CHECK FROM INSIDE THE BASE ALL 3 CLIPS ARE SECURED INTO BASE.

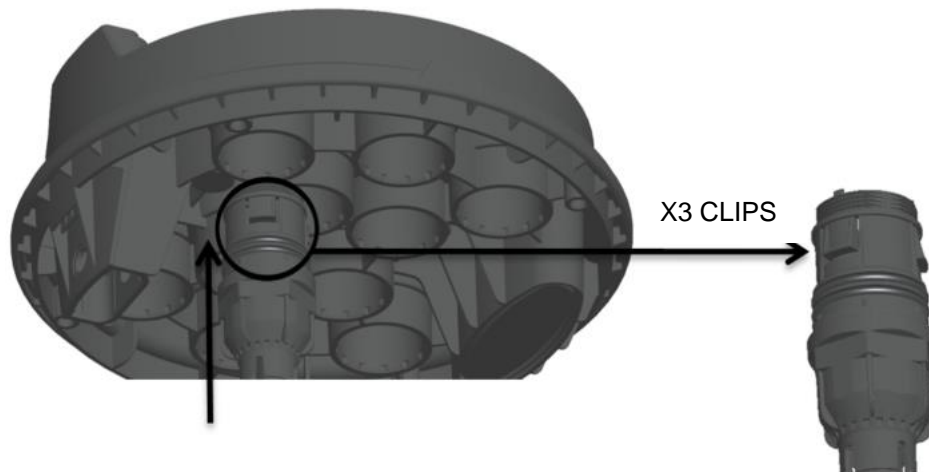

## MECH SEAL – CCJ GLAND INSTALLATION GUIDE

### Step 10

FEED THE RESIN PORT ATTACHMENT (4) OVER THE ELEMENTS, THEN SCREW ONTO THE GLAND ASSEMBLY IN A CLOCKWISE DIRECTION UNTIL THE BOTTOM OF THE RESIN PORT ATTACHMENT MAKES FIRM CONTACT WITH THE BASE (ELEMENTS OMITTED FOR CLARITY).



## MECH SEAL – CCJ GLAND INSTALLATION GUIDE

### Step 11

ATTATCH RESIN PORT TOP PLATE (5) AND INSERT THE GRP THROUGH THE CENTRE HOLE; WHILST DISTRIBUTING THE ELEMENTS EVENLY INTO THE RELEVANT SLOTS.

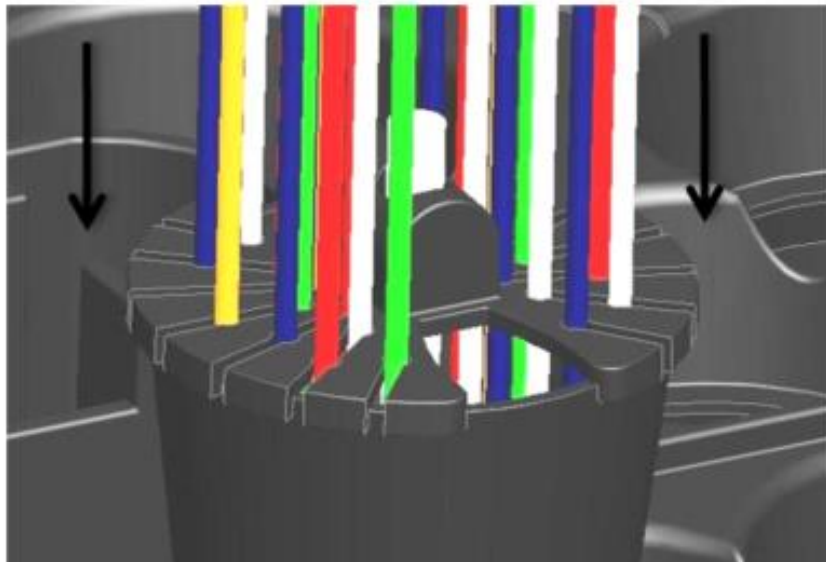

## MECH SEAL – CCJ GLAND INSTALLATION GUIDE

### Step 12

TIGHTEN THE GRUB SCREW (6) ONTO THE GRP USING A 2MM ALLEN KEY.

DO NOT OVER TIGHTEN.

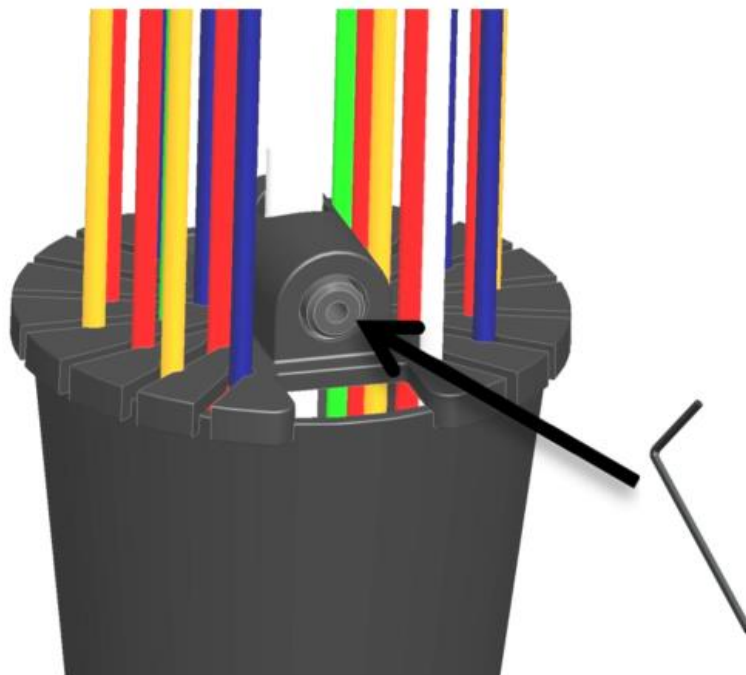

## MECH SEAL – CCJ GLAND INSTALLATION GUIDE

### Step 13

USING THE LARGER SLOT BEHIND THE GRUB SCREW GRADUALLY FILL THE PORT WITH RESIN UNTIL IT IS 5mm FROM THE TOP EDGE.

**DO NOT OVERFLOW.**

ROUTE FIBRES IN ACCORDANCE WITH THE JOINT INSTALLATION GUIDE & APPROVED PRACTICES.

