

In Line Joint (ESDF4.0)

Installation procedure

TABLE OF CONTENTS

INTRODUCTION	p02
TOOLS AND ADDITIONAL ITEMS	p02
KIT CONTENTS.....	p02
CABLE PREPARATION AND INSTALLATION	p03
FIBRE ROUTING AND SPLICING	p14
CLOSING THE JOINT	p22
EARTHING AND PRESSURIZATION	p24
RE-INTERVENTION	p26

Prysmian
Group
INSTALLATION INSTRUCTION

Introduction

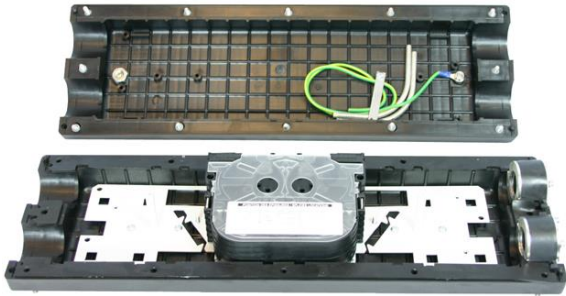

The ESDF4 In Line Joint is an underground joint suitable for direct burial and underground chamber applications. It is used for the jointing and branching of optical cables and has a total capacity of 72 fibres.

The joint is supplied with six splice trays each able to accommodate up to 12 fibre splices. Cable Entry Glands, Splice Protectors and Mounting Brackets are ordered separately to suit the application requirements.

Kit Contents

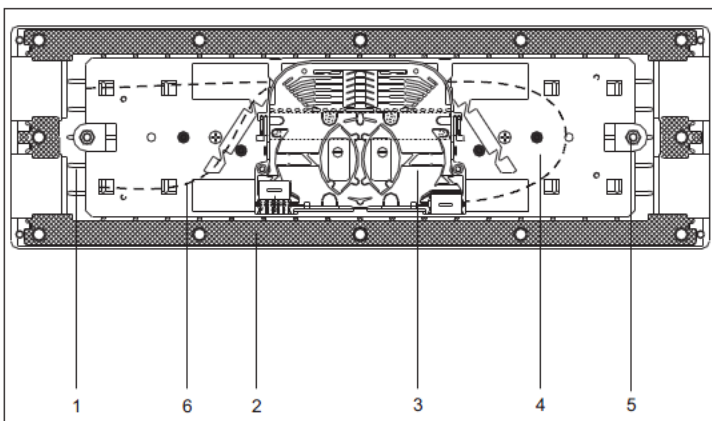

1. Joint Closure (2 shells)
2. Flat Seal
3. Splice Cassettes (6 off)
4. Chassis
5. Earthing Location
6. Fibre Routing Channels

Tools and Additional Items

Tools:

Pozi Drive Screwdriver
M3 Allen Key
Nut Spinner 8mm A/F.
(RS Ref. 499-2335)
Cable Preparation Tools
Fibre Preparation Tools

Additional Items:

Blank Entry Kit	XJTSC00084
Single Cable Entry Kit	XJTSC00085
Double Cable Entry Kit	XJTSC00086
Quad Cable Entry Kit	XJTSC00087

Optional Items:

Wall Mounting Bracket	XJTSC00088
Pole Mounting Bracket	XJTSC00089
Heat Shrink Splice Protectors	XPESC00053

Crimp Splice Protector Kit	XKTSC00020
----------------------------	------------

Cable Preparation and Installation

Step 1

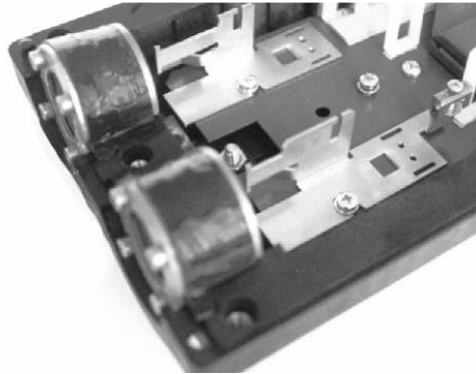

The joint has four cable entry ports, and a cable entry gland must be fitted into all four cable entry ports. In cases where only two or three cables are required to be installed, blank cable entry glands must be installed into the unused ports.

Aside from the blanking gland there are three cable entry glands that can be used for the installation of cables.

- Single Cable Entry - for installation of 1 cable
- Double Cable Entry - for installation of 2 cables
- Quad Cable Entry - for installation of four cables

Cable Preparation and Installation

Step 2

	Seal 1 entry	Seal 2 entries	Seal 4 entries
Adaptor 1	φ 21/16		
Adaptor 2	φ 16,5/12		
Adaptor 3	φ 12,5/8	φ 12,5/8	
Adaptor 4	φ 9/6	φ 9/6	φ 9/6
Adaptor 5		φ 6,5/3,5	φ 6,5/3,5

Each cable entry gland is made up of two plates which are secured together using 4 screws. Between the plates are 5 rubber seals which fit within each other.

Using the table adjacent, first determine the type of gland (1, 2 or 4 entries) and then determine the diameter of the cable being installed. Remove the adaptors that are not required (shown by the shaded-out cells).

The cable must be in contact with the inner diameter of the smallest adaptor.

Cable Preparation and Installation

Step 3

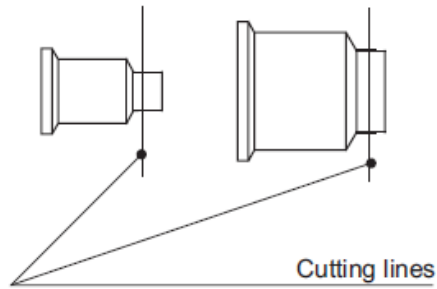

If necessary, cut the end of the adapters 3 and 5 to enable the entry of the cable.

Cable Preparation and Installation

Step 4

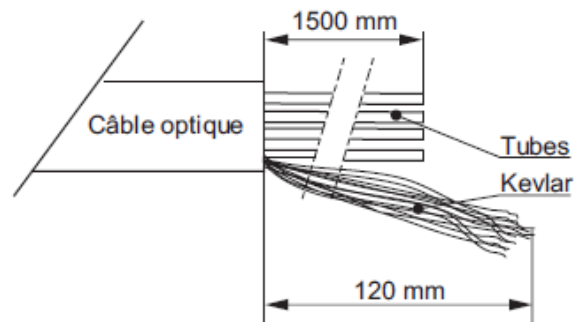

Mark the position of the cable butt at the port of the closure and strip the external sheath from the cable to expose 1500mm of the cable tubes. Cut away any excess cable length.

Cut the Kevlar yarns to 120mm from the cable butt.

Cable Preparation and Installation

Step 5

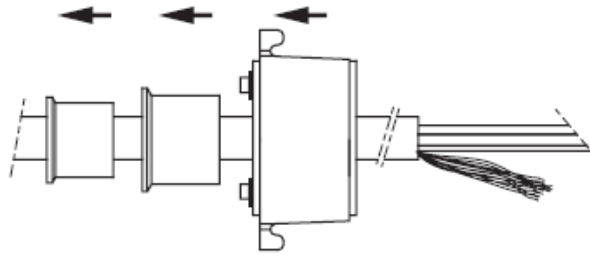

Slip the cable entry gland and the adapters onto the cable. Applying some grease to the cable sheath makes this operation easier.

Cable Preparation and Installation

Step 6

Go to the appropriate step dependent on the type of cable entry gland being installed.

Install the cable onto the appropriate cable clamp. Go to step 7 for a single cable entry, step 8 for a double cable entry or step 9 for a quadruple cable entry.

Cable Preparation and Installation

Step 7

Single Cable Clamp

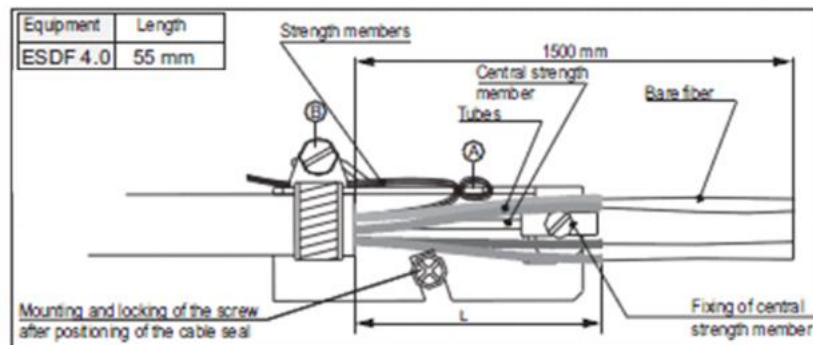

Cut the central strength member to 55mm and secure into bracket as shown.

For the Kevlar yarns, make a loop around the tab A and feed the yarns between the cable sheath and the jubilee clip.



Tighten the jubilee clip around the cable sheath to secure to the bracket.

Cable Preparation and Installation

Step 8

Double Cable Clamp

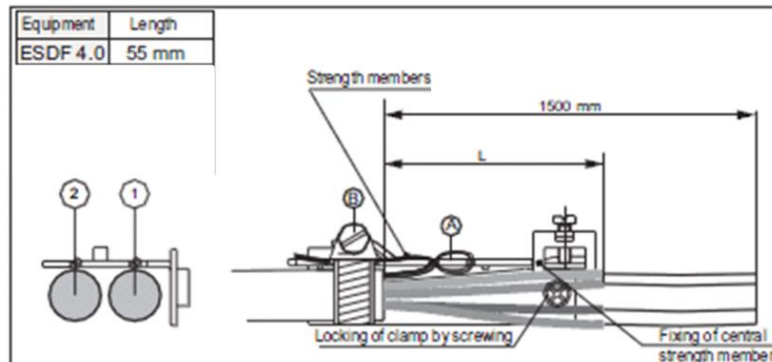

Cut the central strength members to 55mm and secure into bracket as shown.

For the Kevlar yarns, make a loop around the tab A and feed the yarns between the cable sheath and the jubilee clip.



Tighten the jubilee clip around the cable sheath to secure to the bracket.

Note: Mount the cable in the order shown on the drawing to the left.

Cable Preparation and Installation

Step 9

Quadruple Cable Clamp

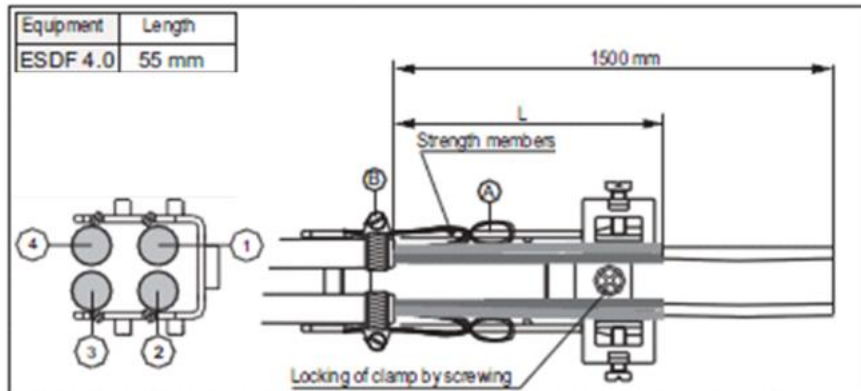

Cut the central strength members to 55mm and secure into bracket as shown.

For the Kevlar yarns, make a loop around the tab A and feed the yarns between the cable sheath and the jubilee clip.



Tighten the jubilee clip around the cable sheath to secure to the bracket.

Note: Mount the cable in the order shown on the drawing to the left.

Cable Preparation and Installation

Step 10

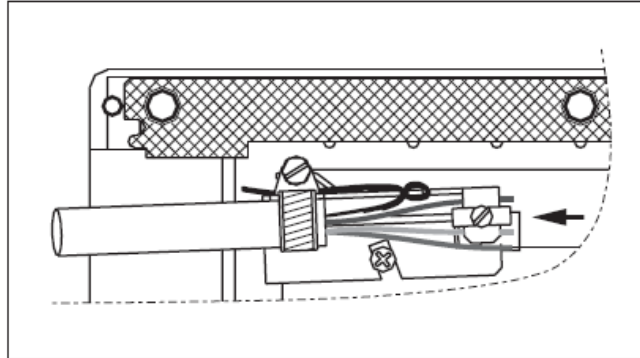

Insert the tabs of the clamping shoe on the bracket into the square holes in the joint chassis. Pull back in the direction shown in the picture to the left.

Locate the M4 screw as shown but do not fully tighten at this stage.

Cable Preparation and Installation

Step 11

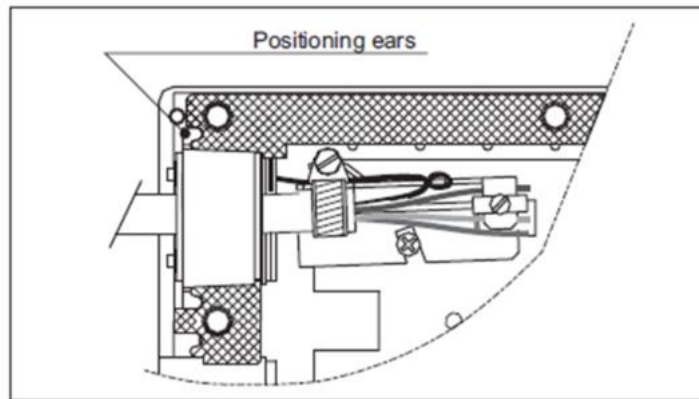

Slip the seals along the cable and seat them into position in the closure body. Ensure that the ears on the seal fit properly within the corresponding cut-outs in the flat seal.

Fully tighten the M4 screw.

Fibre routing and splicing

Step 12

Routing of bare fibres

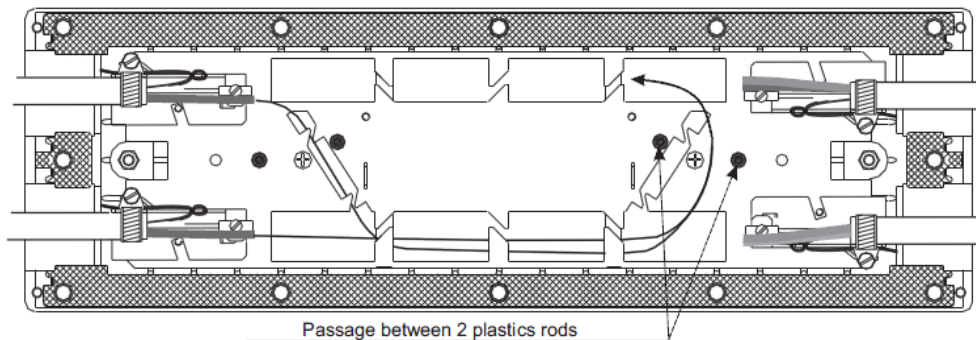

It is possible to route the bare fibres from the cable tubes through the chassis and directly onto the splice tray. When using this method, the fibres can be vulnerable to damage so extreme care should be taken.

The diagram opposite shows the path the fibres should take through the joint chassis. The chassis is totally symmetrical so if routing from the other side follow the same route in the other direction.

Fibre routing and splicing

Step 13

Routing of fibres through spiral wrap tube

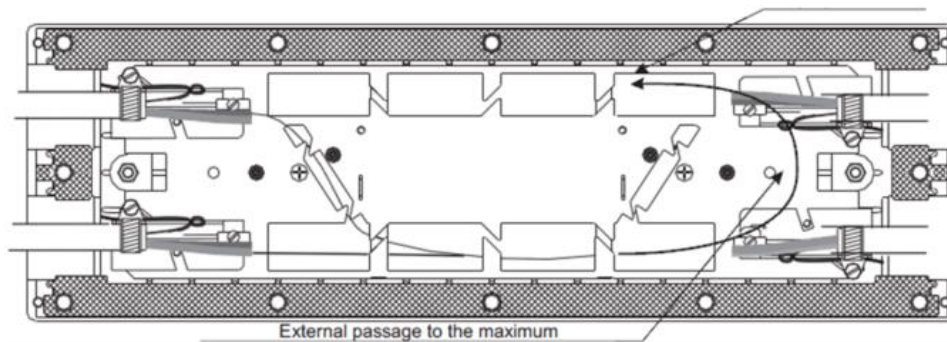

It is possible to route the fibres from the cable tubes through protective spiral wrap tube.

The diagram opposite shows the patch the tube should take through the joint chassis. The chassis is totally symmetrical so if routing from the other side follow the same route in the other direction.

Fibre routing and splicing

Step 14

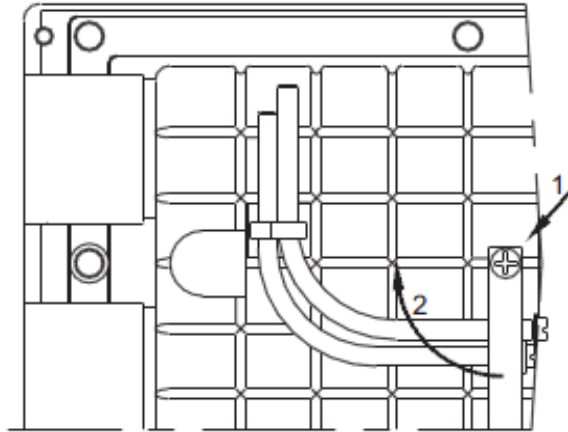

To access different cassettes to enable the routing of fibres onto the splice trays remove the two curved brackets supplied with the joint.

Fibre routing and splicing

Step 15

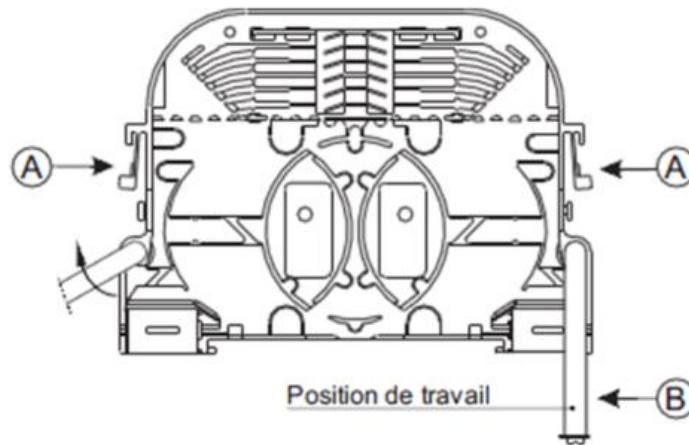

Screw the two brackets into the joint chassis and keep them lined up in the working position indicated opposite.

To remove a tray, press on the clips (A) and slide the tray up to the end of the bracket (B).

Fibre routing and splicing

Step 16

FIBRE ENTRY BY OPPOSITE SIDES

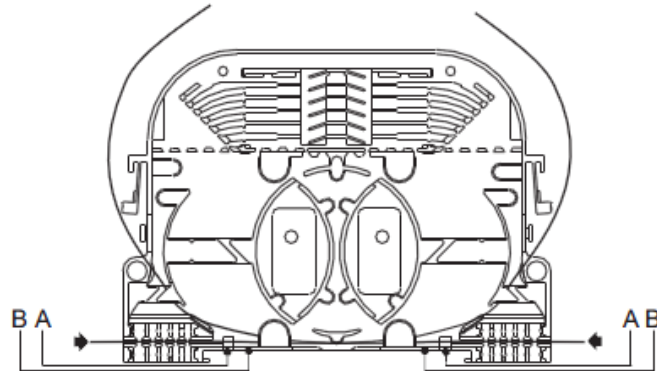

Open the two hinged locking plates on the tube entry ports and enter the fibre as shown by the arrows.

If entering with a tube, then stop the tube at position (B) and secure with a tie wrap in position (A).

Fibre routing and splicing

Step 17

FIBRES ENTERING FROM THE SAME SIDE

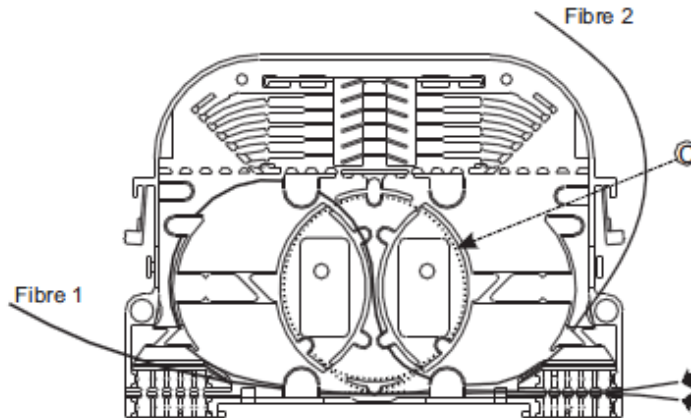

In cases where fibres enter from the same side of the tray, route one of the fibres through the central mandrel channel of the tray to change the routing direction.

In cases where dark or unused fibre is installed, store it inside the central mandrel for use later.

Fibre routing and splicing

Step 18

SPLICING

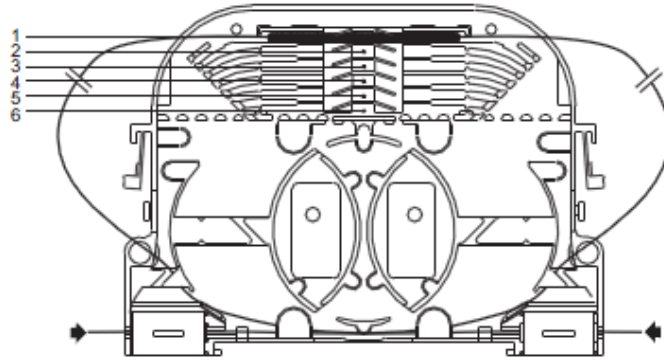

Splice the fibres.

When cool install the splice protector into the splice bay as shown.

Fibre routing and splicing

Step 19

STORAGE OF OVER LENGTH

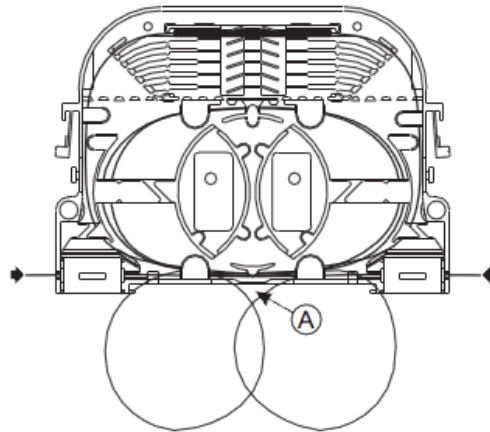

Coil the fibre length around the central storage area of the splice tray ensuring that all the fibres are fully retained beneath the routing tabs of the splice tray.

Replace the tray cover.

Closing the joint

Step 20

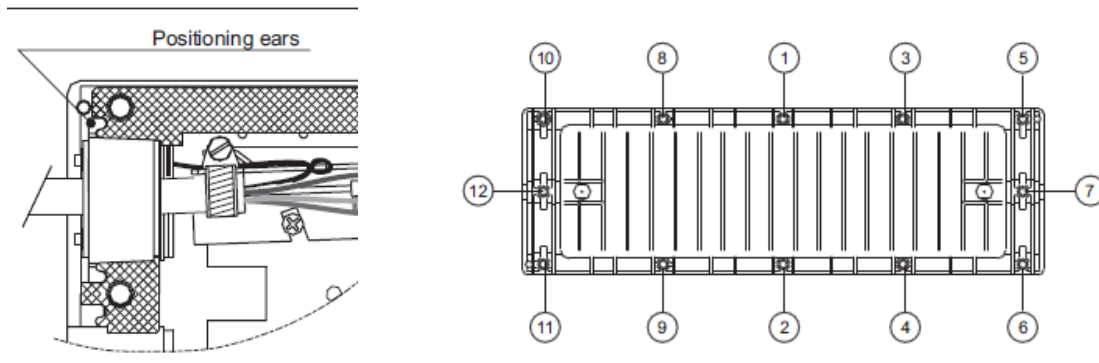

Check that all cable entry seals are correctly located and that the ears of the seals are located within the cut-outs of the flat gasket seal.

Replace the cover.

First-hand tighten the screws in the order sequence shown. Then fully tighten all screws using the same sequence until fully tight. We recommend that a screwdriver type Nut Spinner 8mm A/F is used for this purpose.

Closing the joint

Step 21

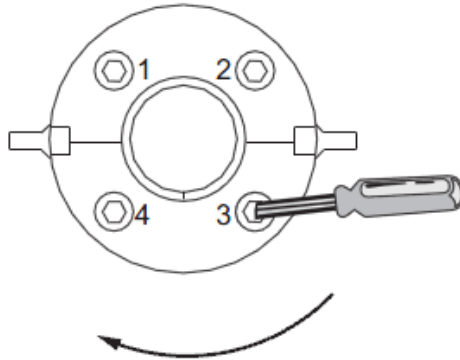

Tighten the seals in the order shown on the diagram opposite. Execute a maximum of two turns per screw before moving to the next screw.

The minimum tightening is shown when the crinkle washer beneath the head of the screw is flat. Do not tighten using an Allen Key. Use a driver as shown.

Earthing and Pressurisation

Step 22

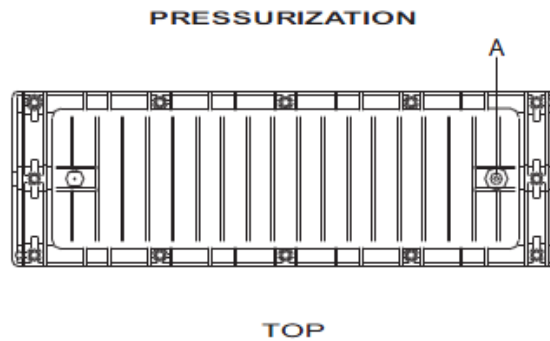

Unscrew the valve cap A. Using a foot pump and a manometer pump the joint up and bleed down to 0.4 bar.

Check for any leaks and if required release the pressure again from the joint by depressing the valve.

Re-fit the valve cap.

Earthing and Pressurisation

Step 23

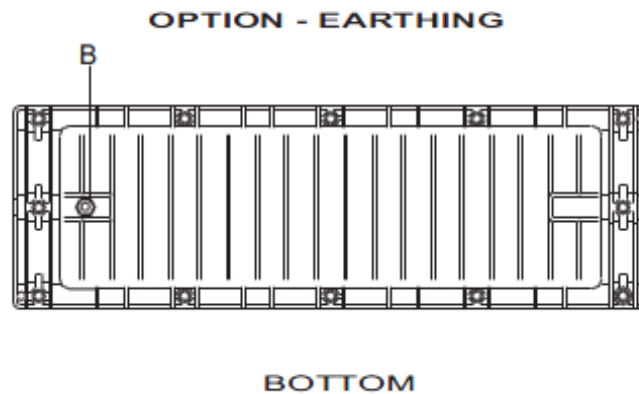

It is possible to earth cables with a metallic strength member by running a length of earth wire from the cable bracket (beneath the screw) to the earthing post of the joint located on the bottom of the joint and shown opposite by the letter B.

Note: The earth wire is not supplied.

Re-intervention

Step 24



De-pressurize the box by depressing the valve in the top cover.

Unscrew the cable entry seals as shown.

Open the box by un-doing the twelve retaining screws shown in step 20.

Re-intervention

Step 25

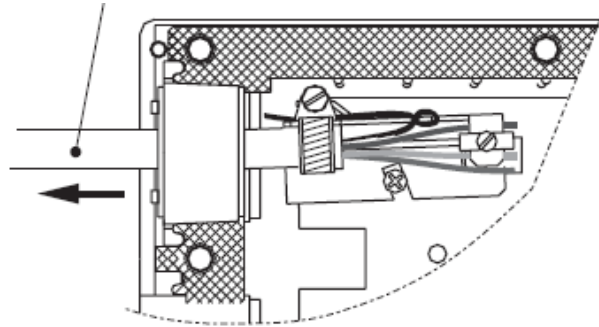

To remove a cable, slip the seals along the cable using grease if required.

Remove the cable or add another cable by following the procedures listed in this document.